



CE



Contents

Important regulations.....	2
Introduction.....	2
Safety information.....	2
Pictogram explanation.....	2
Intended use.....	3
SHEV opening.....	3
Example of application.....	3
Performance features.....	3
Overview of components.....	4
Control module – CM-BT1-D4-P2.....	5
Actuator module – AM-1-2-10-24-D6-D2.....	5
Supply module – PSM-1-24-40.....	5
Trigger module – TMA-1-D4-D12.....	5
Power packs PS-S1-24-20 and PS-S1-24-40.....	6
Technical data.....	7
24 V emergency supply.....	7
Declaration of conformity.....	7
Inner structure of standard control panels.....	8
Arrangement of the modules.....	9
Installation of the module sockets.....	9
Removal of the module sockets.....	9
General instructions for connection.....	10
Wiring diagram (sample).....	10
Connection – PSM.....	11
Connection – CM.....	12
Connection – Digital inputs and outputs on CM, AM and TMA.....	13
Connection – AM.....	14
Connection – Vent buttons to AM.....	14
Connection – AM with ACB drives.....	15
Connection – AM with pole-changing drives.....	15
Connection – TMA.....	16
Connection – TMA (2 lines).....	17
Connection – TMA parallel connection RT.....	18
Connection – TMA to fire alarm system (FAS).....	18
Description of the inputs and outputs.....	19
Commissioning and configuration with the SCS software.....	20
Standard configurations.....	21
Description of the software functions.....	23
Operation - Touch panel (optional).....	24
Operation - Daily ventilation.....	25
Operation - Weather automation.....	25
Operation - SHEV.....	25
Operation - Trigger on alarm.....	26
Operation - Closing after alarm.....	26
Warranty.....	27
Inspection.....	27
Disposal.....	27
Maintenance and cleaning.....	27

Introduction

Your D+H service and sales partner

Safety in the building is not only provided by the product. Safety is created above all by competence. All D+H service and sales partners are certified and regularly trained SHEV specialist companies. They work closely with D+H Mechatronic AG as the manufacturer to implement comprehensive system solutions for SHEV and natural building ventilation. With holistic support and continuous quality assurance in every phase of the project: from consulting, planning and project configuration to installation, commissioning, maintenance and service. This means that the highest national and international quality standards are reliably fulfilled.

Installation and commissioning

The comprehensive network of D+H service and sales partners is available to you for proper installation and commissioning. Our partner system guarantees that D+H products are installed exclusively by trained and experienced technicians in compliance with the technical directives and regulations. Personal transfer and instruction of the operators are included.

Maintenance and repairs

Building operators are responsible for the functional reliability of safety devices in their own buildings.

Regular and proper maintenance ensures that your system will always be operational. As SHEV specialist companies, the D+H service and sales partners are optimally qualified for the maintenance. Owners/operators can demonstrate at any time that they have fulfilled their obligation by means of a service contract.

Quality with a warranty

You receive extended warranty benefits for all D+H SHEV systems that were installed by a D+H service and sales partner and are regularly maintained. Ask your local D+H service and sales partner about this.

Always in your neighbourhood

We are represented around the globe with our network of subsidiaries and exclusive partners.

Looking for a local D+H partner?

Simply visit our website:

www.dh-partner.com

WARNING

Read all the safety information, instructions, images and technical data provided with this product.
Failure to observe the following instructions can result in electric shock, fire and/or serious injury.
Keep all the safety information and instructions in a safe place for future reference.

Important regulations

It is necessary to observe VDE 0833 for danger alarm systems, VdS 2221, VDE 0100 for electrical systems, DIN 18232 for SHEV systems, the provisions of the local fire brigade and of the energy supply company for the mains connection.



Safety information

230 V AC operating voltage!

Risk of injury from electric shock!

- Only an authorised, electrically skilled person is allowed to connect the power
- Keep children away from the controller
- Only use in dry spaces
- Only intended for installation indoors
- Only use unaltered D+H original parts

Pictogram explanation

	Control panel O.K.
	Fault
	SHEV alarm

Intended use

- Modular SHEV controller for complex control tasks
- Can be used in the AdComNet SHEV bus system
- Combine lines and groups however you want
- Convenience functions for daily ventilation
- Only intended for installation indoors

SHEV opening

In case of fire, the SHEV opening should enable flue gases to flow out with as little hindrance as possible.

The size, type and positioning of the SHEV opening is of critical importance for the optimum effect. These specifications are defined in the relevant regulations of the respective country. More information about this is also available at www.rwa-heute.de.

The SHEV opening should be coordinated with the responsible fire prevention authority.

Performance features

- Flexible design for implementing decentralized, central and combined SHEV systems
- AdComNet bus system for seamless networking of the modules within the CPS-M and further D+H AdComNet SHEV control system
- Simple implementation of complex SHEV scenarios
- High flexibility and expandability
- Each control panel functions autonomously when the bus connection fails
- Programming via the D+H Service and Configuration Suite (SCS)
- No specialised system integrator required
- Can be carried out by any trained D+H partner
- The control panel can receive firmware updates via the USB interface on the CM module
- Approved by VdS in accordance with EN 12101-9 and EN 12101-10 (in testing)
- Electrical interconnection of the modules using plug connectors integrated into the bases
- Increase of the drive current in 20 A increments
- Freely selectable group assignment, can be changed at any time
- Max. drive current of 10 A per group or 20 A per actuator module
- All outputs are short-circuit resistant and electronically protected by a fuse
- Assemblies can be retrofitted during building modification
- Lockable surface-mounted sheet steel housing
- Installation of all modules on a 35 mm top hat rail

Example of application

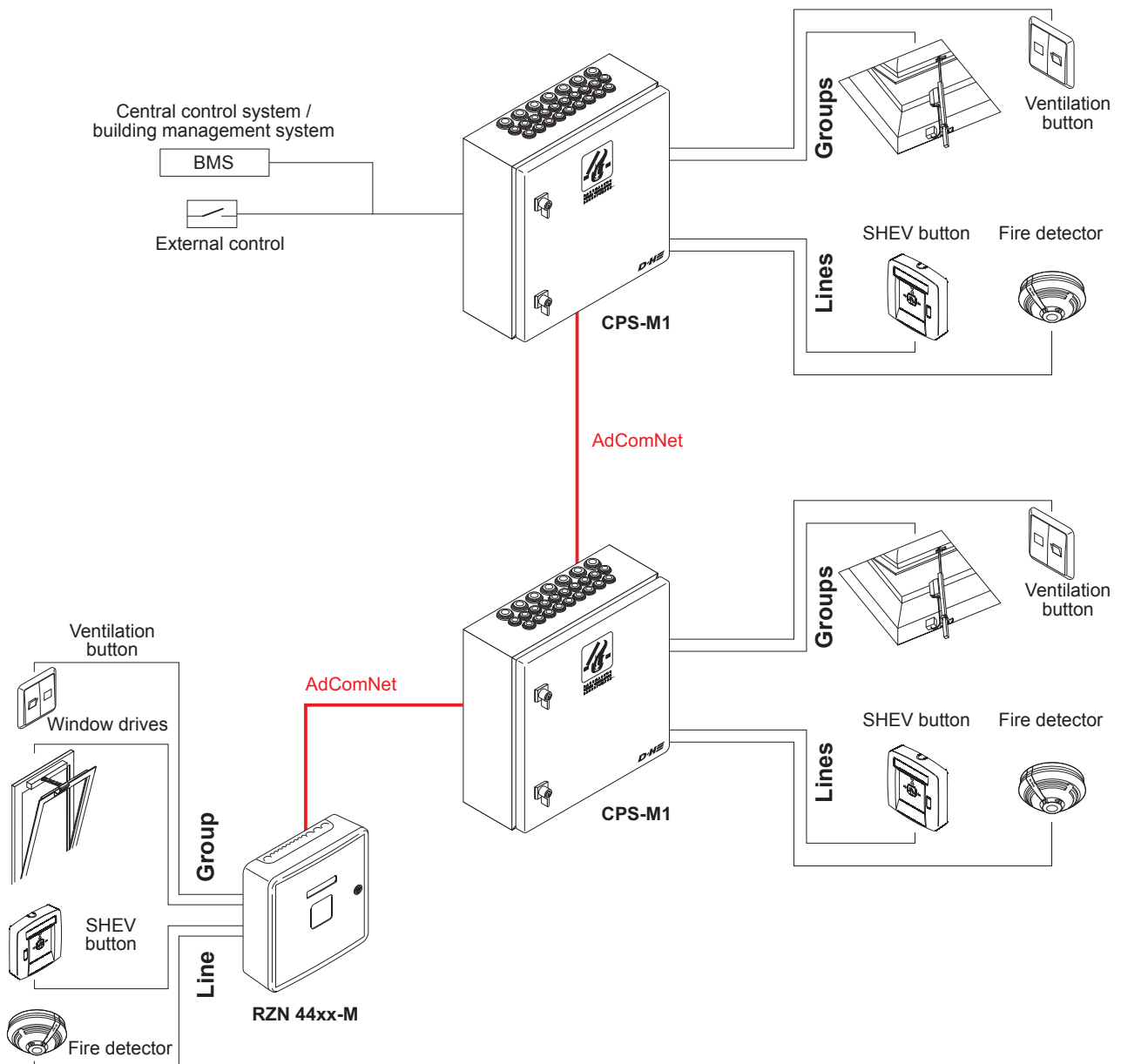

Overview of components

Basic module socket
MS-D1-RR-TS
31.702.40

Supply module socket
MS-S1-RD-TS
31.702.50

Expansion module socket
MS-S1-DD-TS
31.702.60

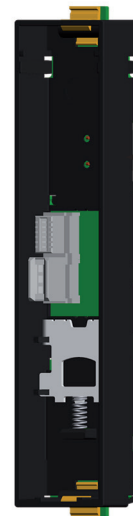
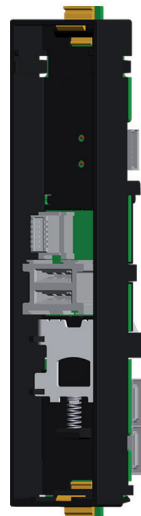
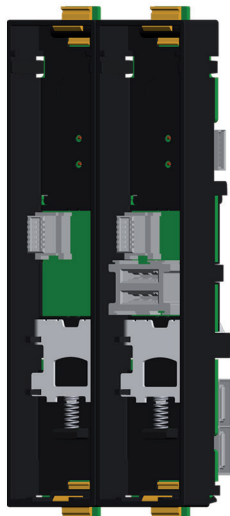

Bus termination module
BTM-1-1
31.702.80
Is plugged into the
last module socket.

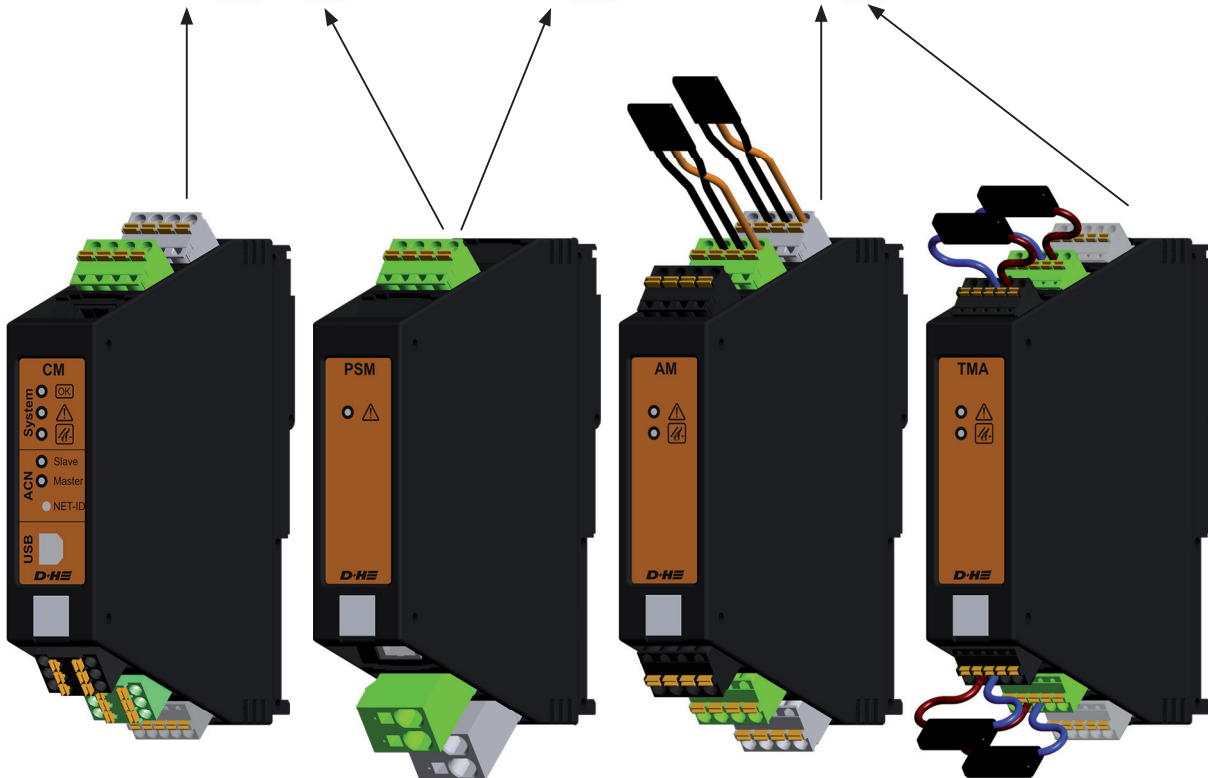
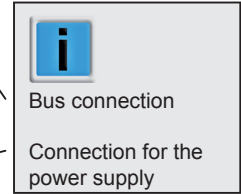

Control module
CM-BT1-D4-P2
31.702.10 (Page 5)

Mains supply module
PSM-1-24-040
31.702.00 (Page 5)

24 V DC actuator module
AM-1-2-10-24-D6-D2
31.702.20 (Page 5)

Analogue trigger module
TMA-1-D4-D12
31.702.30 (Page 5)

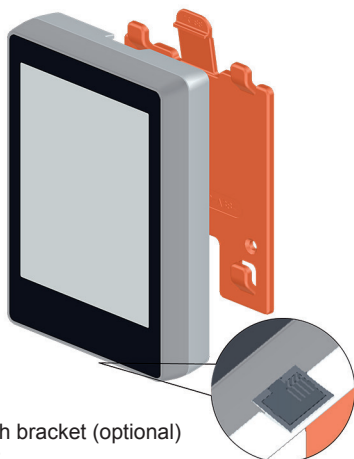

Touch panel with bracket (optional)
TP-C1-35-RJ12
31.702.90 (Page 5)

RJ12 socket



RJ12 connecting cable
CC-TP/TCSU-1000 (1 m)
63.502.63
CC-TP/TCSU-2000 (2 m)
63.502.64

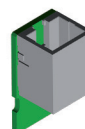

Temperature control sensor unit
TCSU1-RJ12
31.702.70

Control module – CM-BT1-D4-P2

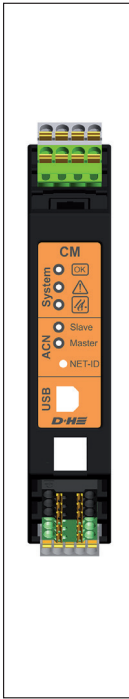

Functions:

- Central control element of the control panel (segment coupler)
- One CM controller module is required for each CPS-M
- Each CM controller module can manage up to 29 additional modules (PSM, AM, TMA)
- AdComNet interfaces for implementing decentralised systems in combination with other AdComNet control panels
- USB interface for configuring the system and for firmware updates of the control panel and the connected drives (only ACB)
- Integrated LEDs to indicate operation (green), fault (yellow), alarm (red) and AdComNet operation
- Status displays for all modules of the respective CPS-M as well as emergency operation of the individual lines and groups using the 3.5" TFT touch panel
- Three user-programmable digital inputs for connecting buttons, switches, external controls etc.
- Two user-programmable, isolated change-over contacts, for example, for fault and alarm notifications
- Connection using removable spring-type terminals
- Conductor cross-sections max. 1.5 mm² Flexible
- Dimensions WxHxD: 26x130x125 mm
- Installation on a 35 mm top hat rail in combination with a basic module socket

Supply module – PSM-1-24-40

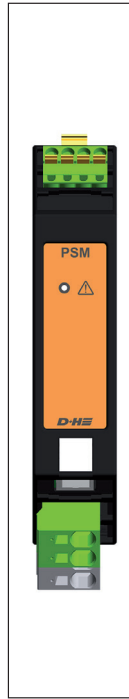

Functions:

- Power supply of the control panel system
- Max. 40 A load current for each supply module depending on the power supply unit
- If a load current of more than 40 A is required, another PSM (including supply module socket) can be used.
- The PSM always provides power to the actuator and trigger modules used to the right of it
- Automatic toggling between mains supply and battery supply in case of a mains outage
- Max. battery capacity 26 Ah (battery type 6)
- 72 hours of emergency supply time
- Integrated protection against excessive discharge
- Temperature-controlled charging voltage with external temperature sensor
- Integrated LED to indicate a fault (yellow)
- Two connections for peripherals that are and are not supplied with emergency power
- Connection using removable spring-type terminals
- Conductor cross-sections max. 2.5 mm² flexible or for supply and battery 6 mm² flexible
- Dimensions WxHxD: 26x130x125 mm
- Installation on a 35 mm top hat rail in combination with a basic module socket or for more than one power supply unit with a supply module socket

Actuator module – AM-1-2-10-24-D6-D2

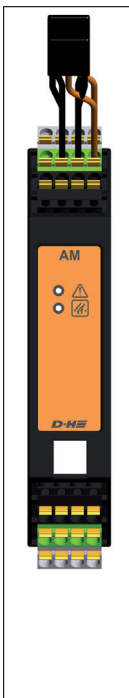

Functions:

- Module for connecting 24 V DC actuators
- 2 independent groups for connecting drives, each with a total maximum current of 10 A
- The cable is monitored for breaks and short circuits via the terminal module EM-47K
- Each group is electronically protected against overload
- 6 user-programmable digital inputs (e.g. ventilation button)
- 2 user-programmable digital outputs (e.g. NOT CLOSED signal)
- 2 integrated ACB interfaces for reading out and configuring the connected ACB drives
- Can be used with 24 V DC pole-changing drives and ACB drives
- Adjustable ventilation time and opening width for everyday ventilation
- Integrated LEDs to indicate a fault (yellow) and alarm (red)
- Connection using removable spring-type terminals
- Conductor cross-sections max. 2.5 mm² Flexible
- Dimensions WxHxD: 26x130x125 mm
- Installation on a 35 mm top hat rail in combination with an expansion module socket

Trigger module – TMA-1-D4-D12

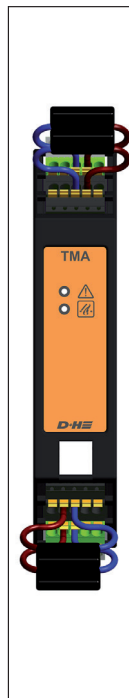

Functions:

- Module for connecting trigger peripheral devices
- Two independent lines for connecting a max. of 10 SHEV buttons and 30 fire detectors per line (only detectors approved by D+H may be used)
- Cables are monitored by the EM-L01 terminal module
- The SCS software can be used to configure the lines also as user-programmable digital inputs and outputs
- Integrated LEDs to indicate a fault (yellow) and alarm (red)
- Connection using removable spring-type terminals
- Conductor cross-sections max. 1.5 mm² Flexible
- Dimensions WxHxD: 26x130x125 mm
- Installation on a 35 mm top hat rail in combination with an expansion module socket

Power packs PS-S1-24-20 and PS-S1-24-40

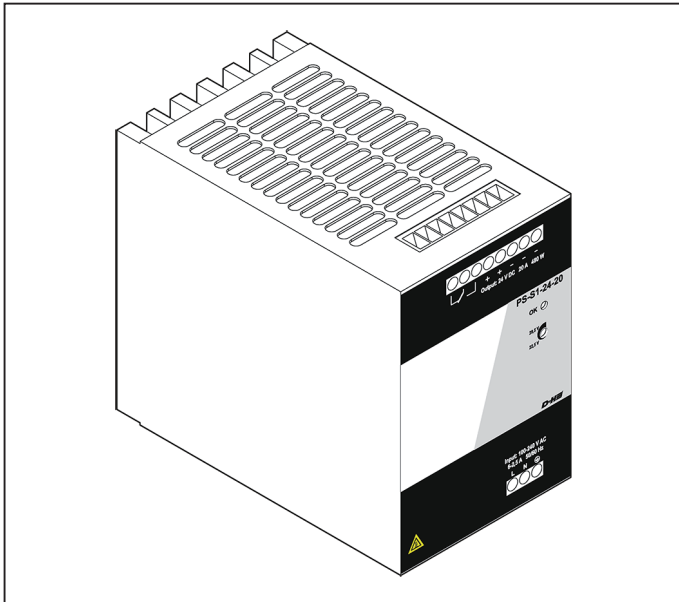

Functions:

- Output: 24 V DC, 20 A or 40 A
- Installation on 35 mm top hat rail
- Low ripple
- Reverse-voltage protected and short-circuit resistant
- Multiple power supply units can be combined
- For each power supply unit, one PSM supply module is needed

Technical data:

Type	PS-S1-24-20
Rated input voltage	230 V AC \pm 15%
Frequency	45 to 65 Hz
Nominal power	530 VA / 480 W
Output voltage	24 V DC \pm 1%
Ripple	< 50 mVSS
Output current	20 A
Short-circuit resistant	YES
Can be connected in parallel	YES
Reverse-voltage protected	YES
Input line connection	max. 6 mm ² star / max. 4 mm ² flexible
Output line connection	max. 6 mm ² star / max. 4 mm ² flexible
Dimensions WxHxD	90x130x150 mm

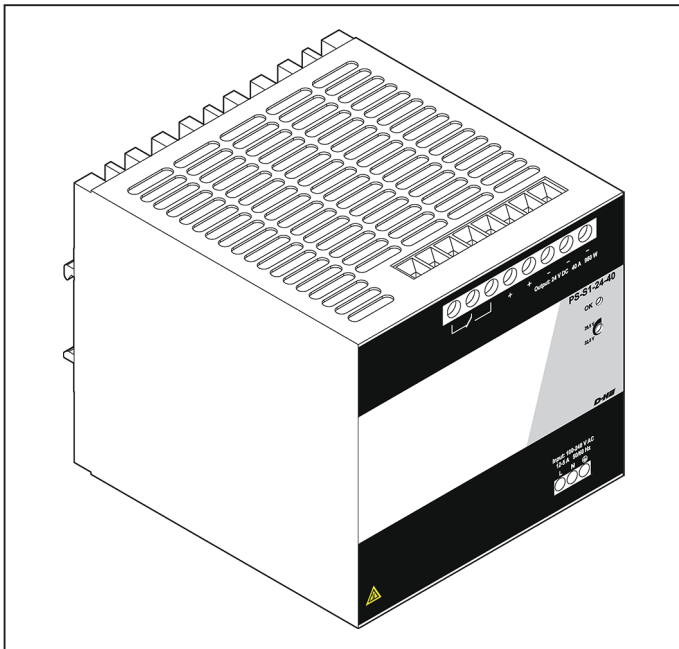

Type	PS-S1-24-40
Rated input voltage	230 V AC \pm 15%
Frequency	45 to 65 Hz
Nominal power	1040 VA / 960 W
Output voltage	24 V DC \pm 1%
Ripple	< 50 mVss
Output current	40 A
Short-circuit resistant	YES
Can be connected in parallel	YES
Reverse-voltage protected	YES
Input line connection	max. 6 mm ² star / max. 4 mm ² flexible
Output line connection	max. 16 mm ² star / max. 16 mm ² flexible
Dimensions WxHxD	140x130x150 mm

Conne- ction	Description
L	Phase
N	Neutral
PE	Protective earth
+	24 V DC output
-	

Technical data

Type	CPS-M1-020-xxxx	CPS-M1-040-xxxx	CPS-M1-060-xxxx	CPS-M1-080-xxxx
Supply	230 V AC, ± 15%, 45 to 60 Hz			
Performance Performance in standby	530 VA / 480 W ca. 7.5 W	1040 VA / 960 W ca. 8.5 W	1570 VA / 1440 W ca. 16 W	2080 VA / 1920 W ca. 17 W
Output voltage Ripple	24 V DC ± 1% < 50 mV _{SS}			
Nominal output current	20 A	40 A	60 A	80 A
Mode of operation - Monitoring - Alarm state / ventilation	Continuous duty Short-time duty (30 % duty cycle)			
Housing	Sheet steel			
Colour	RAL 7035, light grey			
Type of protection	IP 54 (VdS IP 30)			
Protection class	I			
Temperature range	-5 to +40 °C			
Air humidity	5% to 95% RH			
Dimensions W x H x D	500 × 500 × 210 mm	600 × 800 × 250 mm	600 × 800 × 250 mm	800 × 1000 × 300 mm

24 V emergency supply

- Emergency supply time: 72 hours
- Only use VdS-approved batteries.
- The sum of the nominal currents of the drives and actuators that are triggered when there is an alarm must not exceed the max. permitted load of the respective battery type
- The required battery capacity has to be determined for each PSM.
- The sum of the required ampere-hours (Ah) of all components, including a 30% reserve, must be smaller than the capacity of the battery

Standard batteries:

For each PS-S1-24-20 (+PSM): 2 x battery type 5 (12 V, 18 Ah ± 15%)

For each PS-S1-24-40 (+PSM): 2 x battery type 6 (12 V, 26 Ah ± 15%)

Battery type	Max. permitted load through drives / actuators
Battery type 4 (12 Ah ± 15%)	24 A
Battery type 5 (18 Ah ± 15%)	36 A
Battery type 6 (26 Ah ± 15%)	52 A

Components	Approx. Ah required for 72 hours
Intrinsic consumption by CM	0.52 Ah
CM supply of the modules	0.018 Ah per module
PSM	0.29 Ah
TMA	0.58 Ah
AM	0.43 Ah
Fire detector	0.005 Ah
Smoke vent button	0.014 Ah
Drives / actuators for 180 sec.	0.18 Ah (for each 1 A nominal current)
Alarm devices 250 mA for 180 sec.	0.045 Ah
Devices and digital outputs with an emergency supply (can be adjusted using SCS)	7.2 Ah (for each 100 mA output current)
Digital outputs with an emergency supply (can be adjusted using SCS)	3.6 Ah (for each 50 mA output current)
Touch panel	0.4 Ah
Required capacity = Sum of the required Ah plus a 30% reserve	

Declaration of conformity

We declare under our sole responsibility that the product described under "Technical Data" complies with the following directives:

2014/30/EU, 2014/35/EU, EU 305/2011

Technical documents stored at:

D+H Mechatronic AG, D-22949 Ammersbek

Dirk Dingfelder Maik Schmees
CEO Authorised Officer, Technical Director
12.10.2017

Inner structure of standard control panels

CPS-M1-020-xxxx

Fig.: CPS-M1-020-0202

Standard equipment

31.700.10	CPS-M1-020-0202	CM PSM AM TMA
31.700.15	CPS-M1-020-0204	CM PSM AM AM TMA
31.700.20	CPS-M1-020-0404	CM PSM AM AM TMA TMA
31.700.25	CPS-M1-020-0606	CM PSM AM AM AM TMA TMA TMA

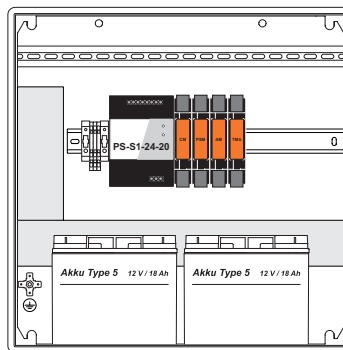

CPS-M1-040-xxxx

Fig.: CPS-M1-040-0204

Standard equipment

31.700.30	CPS-M1-040-0204	CM PSM AM AM TMA
31.700.35	CPS-M1-040-0206	CM PSM AM AM AM TMA
31.700.40	CPS-M1-040-0404	CM PSM AM AM TMA TMA
31.700.45	CPS-M1-040-0406	CM PSM AM AM AM TMA TMA
31.700.50	CPS-M1-040-0606	CM PSM AM AM AM TMA TMA TMA

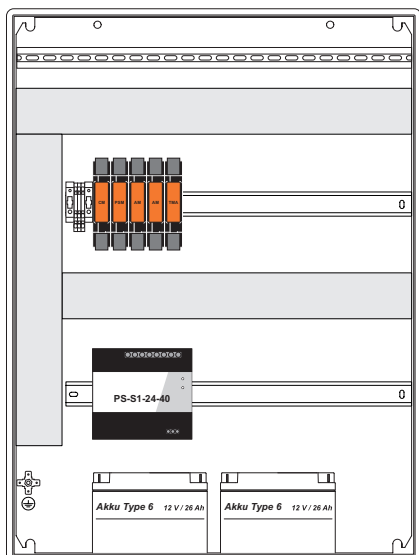

CPS-M1-060-xxxx

Fig.: CPS-M1-060-0206

Standard equipment

31.700.55	CPS-M1-060-0206	CM PSM AM AM PSM AM TMA
31.700.60	CPS-M1-060-0208	CM PSM AM AM PSM AM AM TMA
31.700.65	CPS-M1-060-0210	CM PSM AM AM AM PSM AM AM TMA
31.700.70	CPS-M1-060-0406	CM PSM AM AM PSM AM TMA TMA
31.700.75	CPS-M1-060-0408	CM PSM AM AM PSM AM AM TMA TMA
31.700.80	CPS-M1-060-0410	CM PSM AM AM AM PSM AM AM TMA TMA

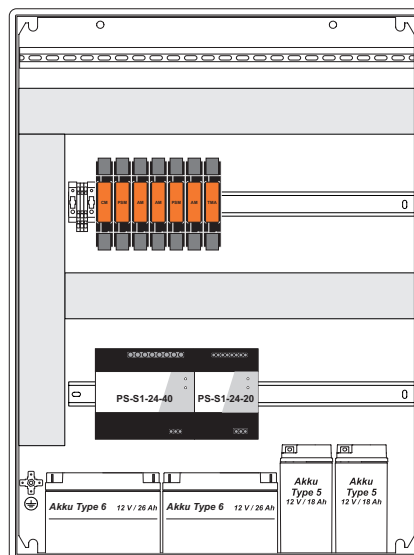

CPS-M1-080-xxxx

Fig.: CPS-M1-020-0208

Standard equipment

31.700.85	CPS-M1-080-0208	CM PSM AM AM PSM AM AM TMA
31.700.90	CPS-M1-080-0210	CM PSM AM AM AM PSM AM AM TMA
31.701.35	CPS-M1-080-0216	CM PSM AM AM AM AM PSM AM AM AM TMA
31.700.95	CPS-M1-080-0408	CM PSM AM AM PSM AM AM TMA TMA
31.701.00	CPS-M1-080-0410	CM PSM AM AM AM PSM AM AM TMA TMA
31.701.05	CPS-M1-080-0608	CM PSM AM AM PSM AM AM TMA TMA TMA
31.701.10	CPS-M1-080-0610	CM PSM AM AM AM PSM AM AM TMA TMA TMA
31.701.15	CPS-M1-080-0808	CM PSM AM AM PSM AM AM TMA TMA TMA TMA
31.700.20	CPS-M1-080-0810	CM PSM AM AM AM PSM AM AM TMA TMA TMA TMA
31.701.25	CPS-M1-080-1010	CM PSM AM AM AM PSM AM AM TMA TMA TMA TMA TMA

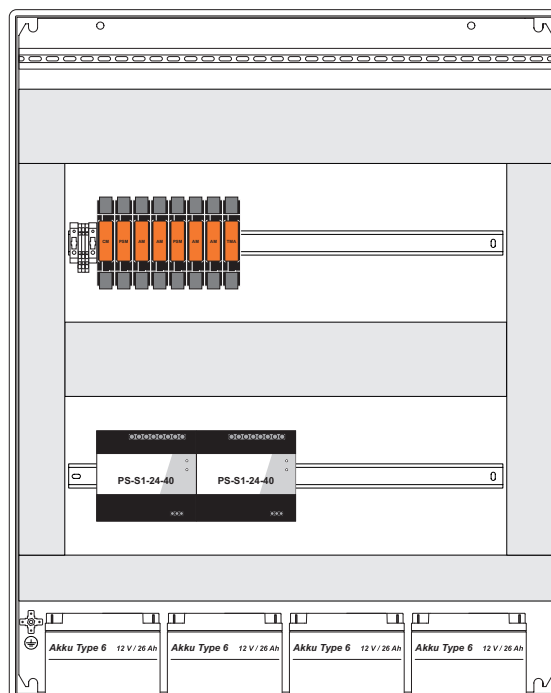

Arrangement of the modules

- Each CM controller module can manage up to 29 additional modules (PSM, AM, TMA)
- The first PSM provides power to the CM module as well as to the AM and TMA modules to the right of it
- Each additional PSM always provides power only to the AM and TMA modules to the right of it
- This applies also to the emergency battery power. Therefore, the AM and TMA modules are to be distributed evenly across the PSM modules
- Due to the higher current consumption and shorter cable paths, the AM modules are each to be used first next to the PSM module
- The total current of the drives respectively connected to the PSM must not exceed the output current of the respective power supply unit.

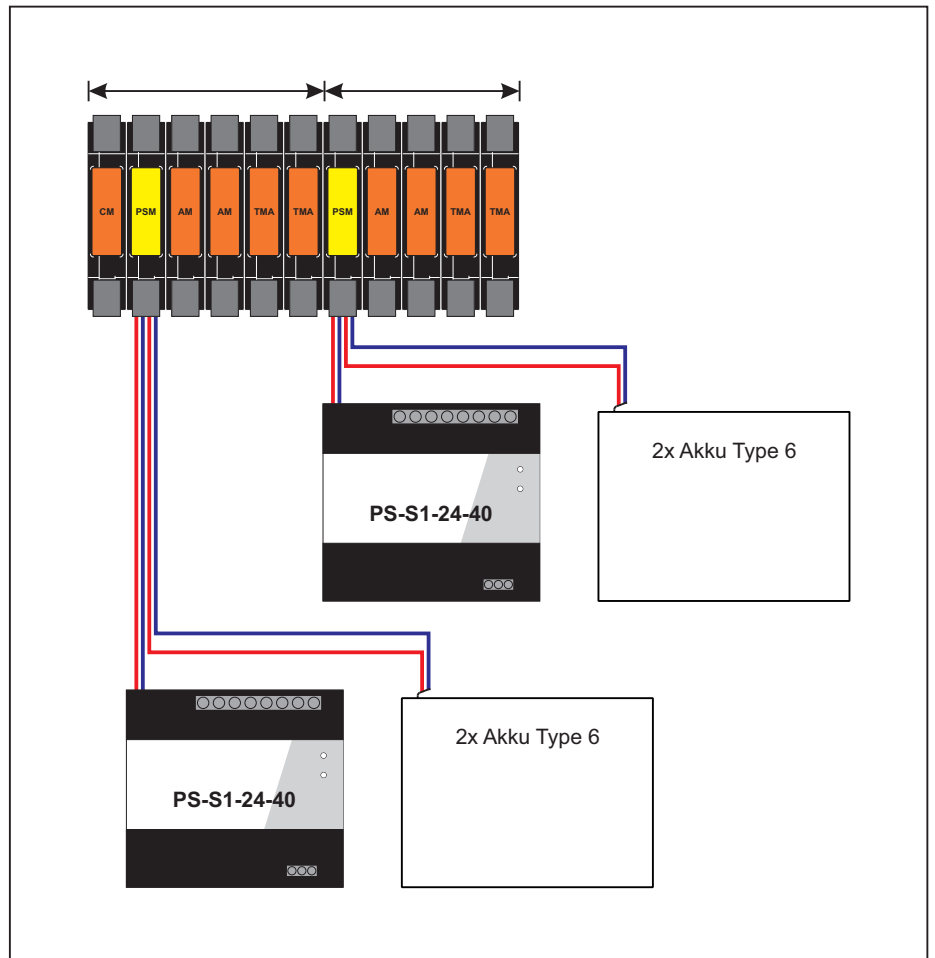

Installation of the module sockets

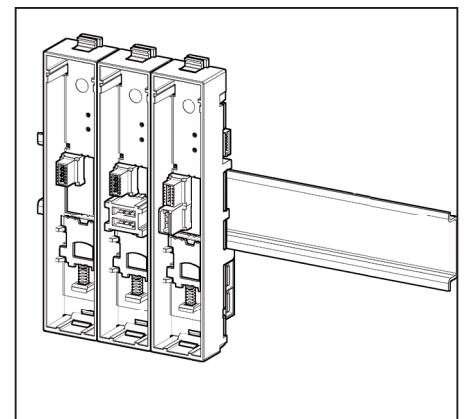
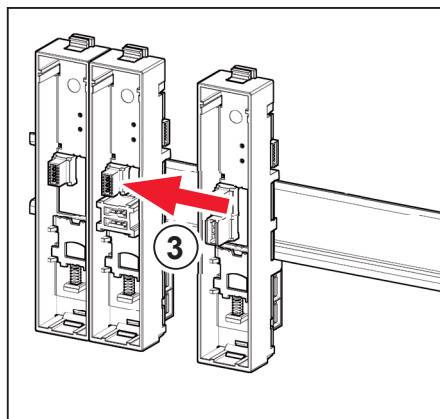
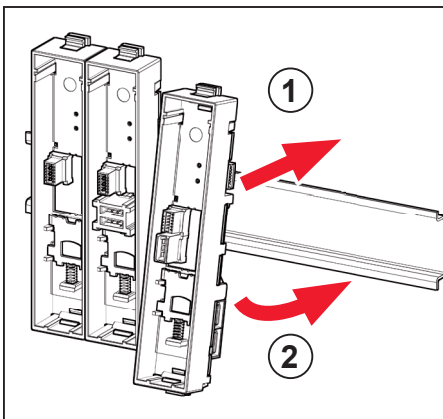

Removal of the module sockets

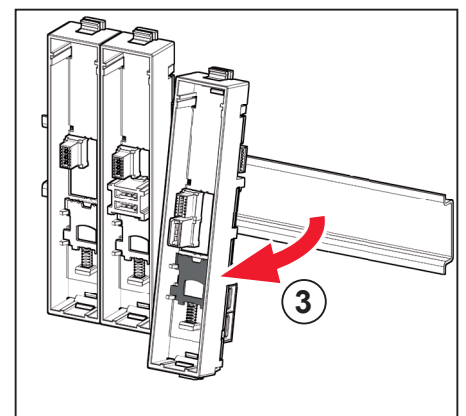
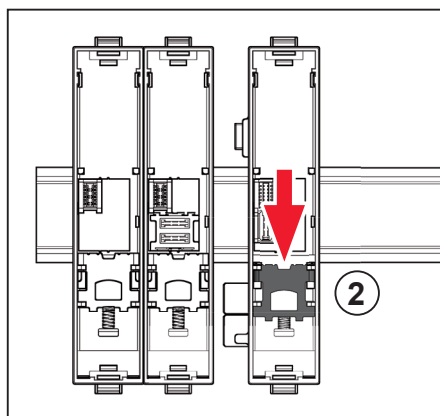
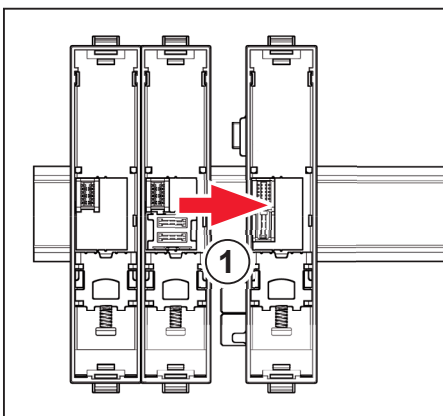

General instructions for connection

- The connections, particularly the earth connections, may be connected to the respective associated PSM supply module and components only.
- System voltage 24 V!
- Do not route cables together with high-voltage cables!
- When cables have a protective earth (green/ yellow) this must not be used!
- No cross-flow of current may occur.
- Shields and additional cables must be connected separately.
- Mark cables and terminal boxes.

Wiring diagram (sample)

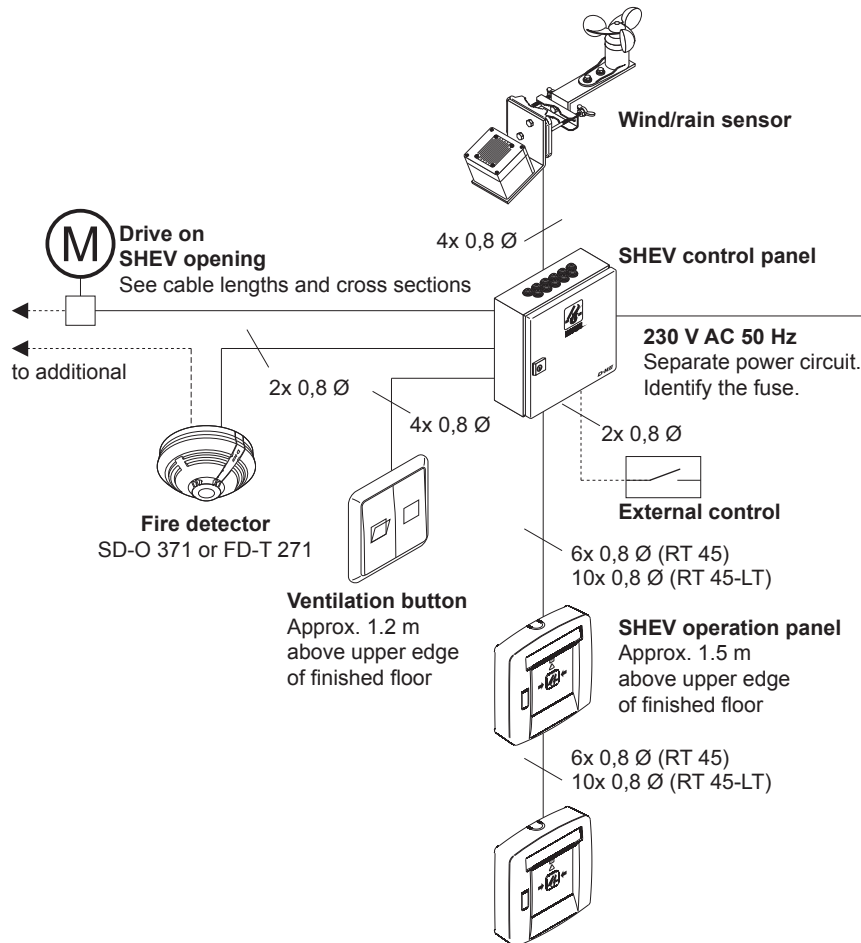

Cables for D+H SHEV systems

When selecting and routing cables, regional installation requirements pertaining to electric cable systems and necessary safety devices, and/or directives pertaining to maintaining the function of electrical cables must be observed (e.g. MLAR guidelines for the fire protection requirements to be met by cable systems in Germany).

Note:

Due to the variety available on the market, no type designations are specified for these cables. Please contact your D+H Partner for this information.

Cable line (control panel - detector)

The cables are monitored for short circuits and line breaks.

Cable group (control panel - drive)

At least three-wire design:

- **2 wires** for supplying the drive (**Mot.a/Mot.b**)
- For **pole-changing drives**, **1 additional wire** for cable monitoring, through which the SHEV high-speed (HS) signal is also transmitted to the drive.
- For **ACB drives**, **2 additional wires** for the bus connection.

Cable lengths and cross sections for Mot.a and Mot.b

Total current	1	2	3	4	5	6	7	8	9	10	
2 x 1.5 mm ²	120	60	40	30	24	20	17	15	13	12	m
2 x 2.5 mm ²	200	100	65	50	40	33	28	25	22	20	m

$$\text{Cross-section (mm}^2\text{)} = \frac{\text{cable length (m)} \times \text{total current}}{80}$$

Connection – PSM

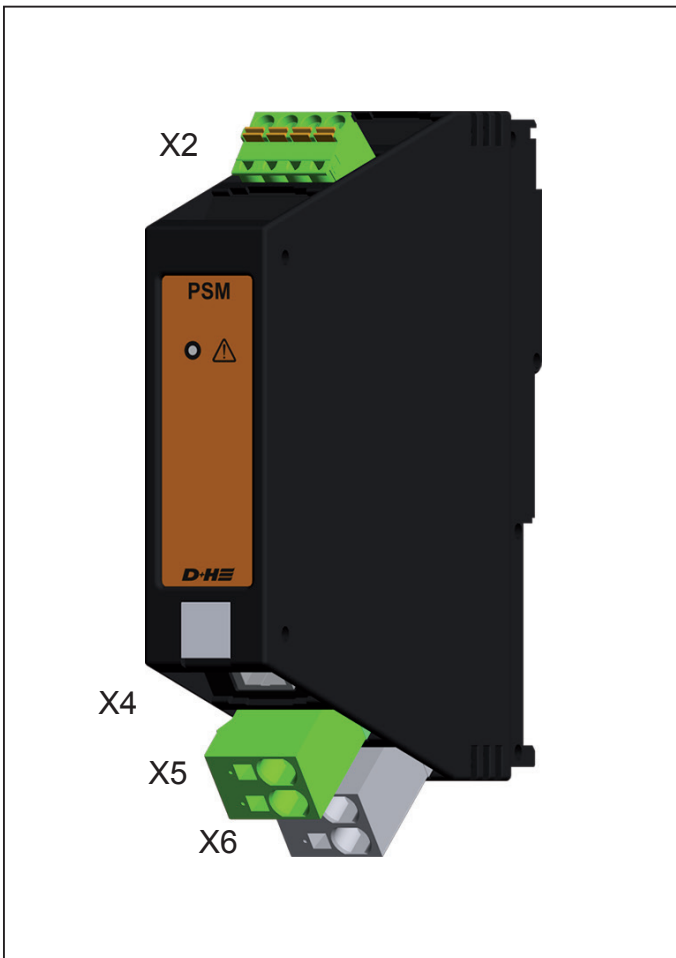

No.	Name	Description
X2.1	N+	Output potential without an emergency supply for ventilation functions, max. 500 mA
X2.2	-	Reference potential (do not connect to P-)
X2.3	+	Output potential with an emergency supply, max. 500 mA
X2.4	-	Reference potential (do not connect to P-)
X4	TCSU1	RJ12 connection of external battery temperature sensor
X5.1	BATT+	Secondary power supply (battery), max 40 A
X5.2	BATT-	
X6.1	SNT+	Primary power supply (power pack), max 40 A
X6.2	SNT-	

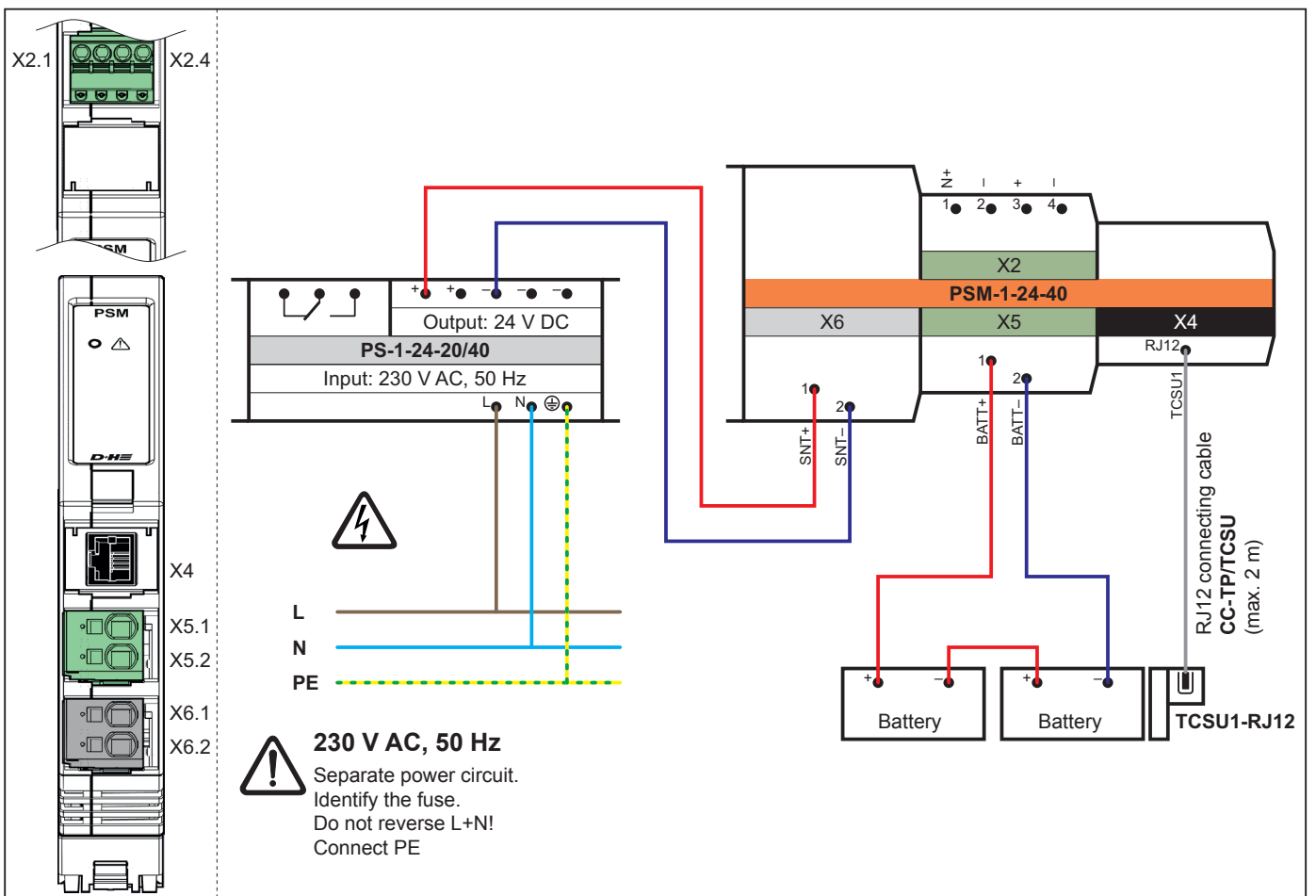

Connection – CM

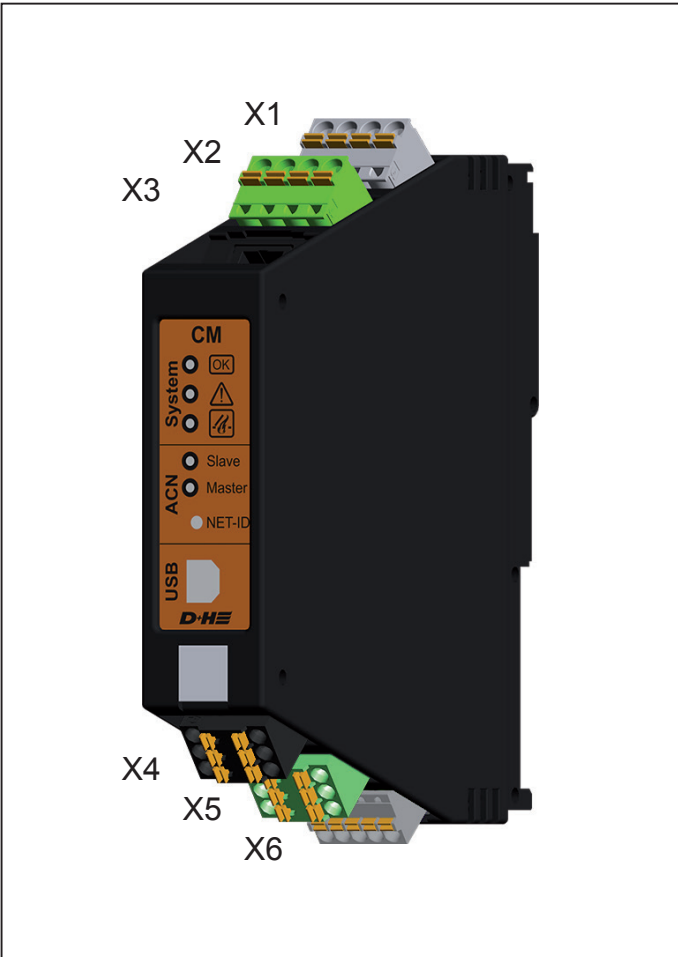

No.	Name	Description
X1.1	n.c.	n.c.
X1.2	NO 1	Isolated change-over contact, max. 35 V / 1 A, general malfunction (factory setting, can be programmed using SCS)
X1.3	COM 1	
X1.3	NC 1	
X2.1	n.c.	n.c.
X2.2	NO 2	Isolated change-over contact, max. 35 V / 1 A, collective alarm (factory setting, can be programmed using SCS)
X2.3	COM 2	
X2.4	NC 2	
X3	TP-C1	RJ12 connection for external touch panel
X4.1	ACN D+	AdComNet master interface
X4.2	ACN D-	
X4.3	Shield	
X5.1	ACN D+	AdComNet slave interface
X5.2	ACN D-	
X5.3	Shield	
X6.5	n.c.	n.c.
X6.4	DI 1.1	Freely configurable digital input, 0 to 28 V, active minus or plus, control panel OPEN (factory setting, can be programmed using SCS)
X6.3	DI 1.2	
X6.2	DI 1.3	Freely configurable digital input, 0 to 28 V, active minus or plus
X6.1	-	Reference potential (do not connect to P-)

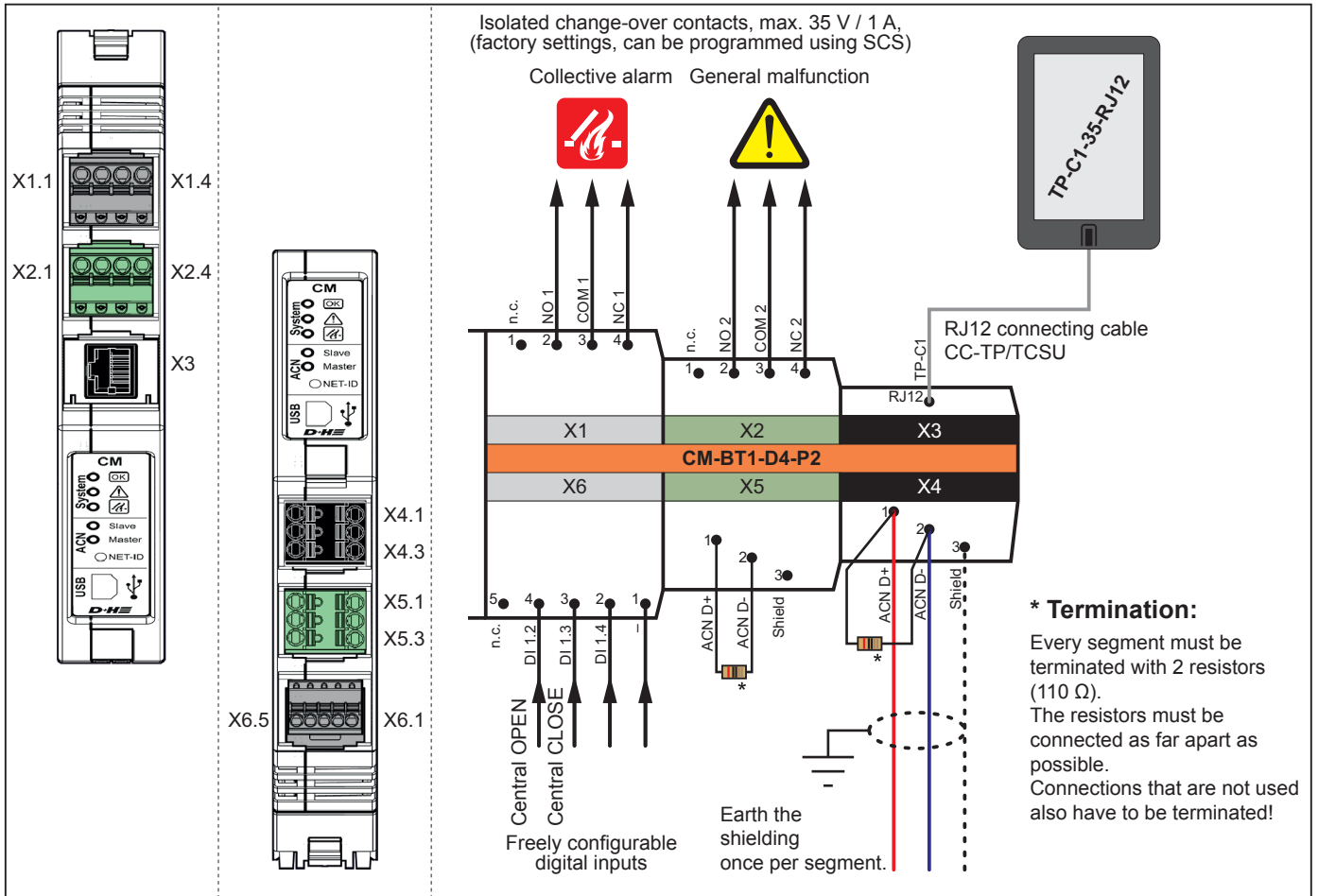

Connection – Digital inputs and outputs on CM, AM and TMA

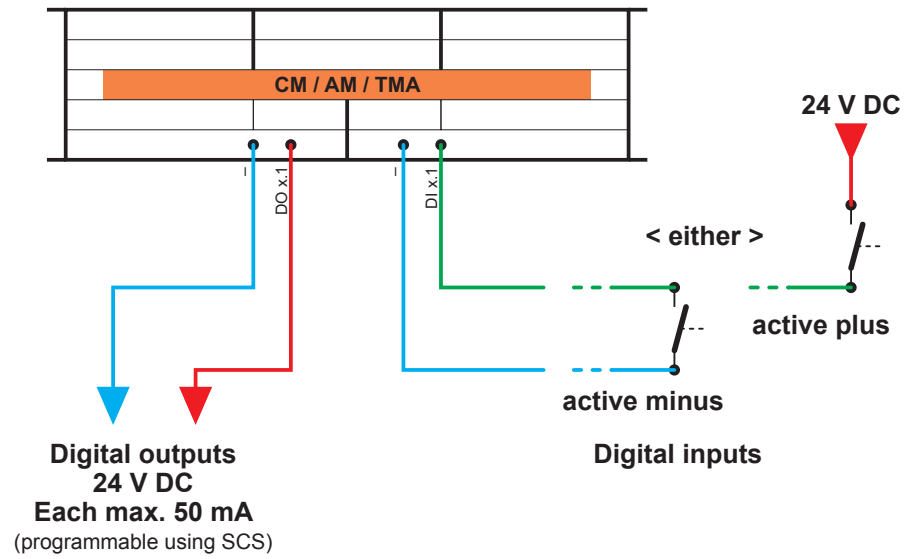

Contact	Inverted	Signal
Open	Off	0
Closed	Off	1
Open	On	1
Closed	On	0

Connection – AM

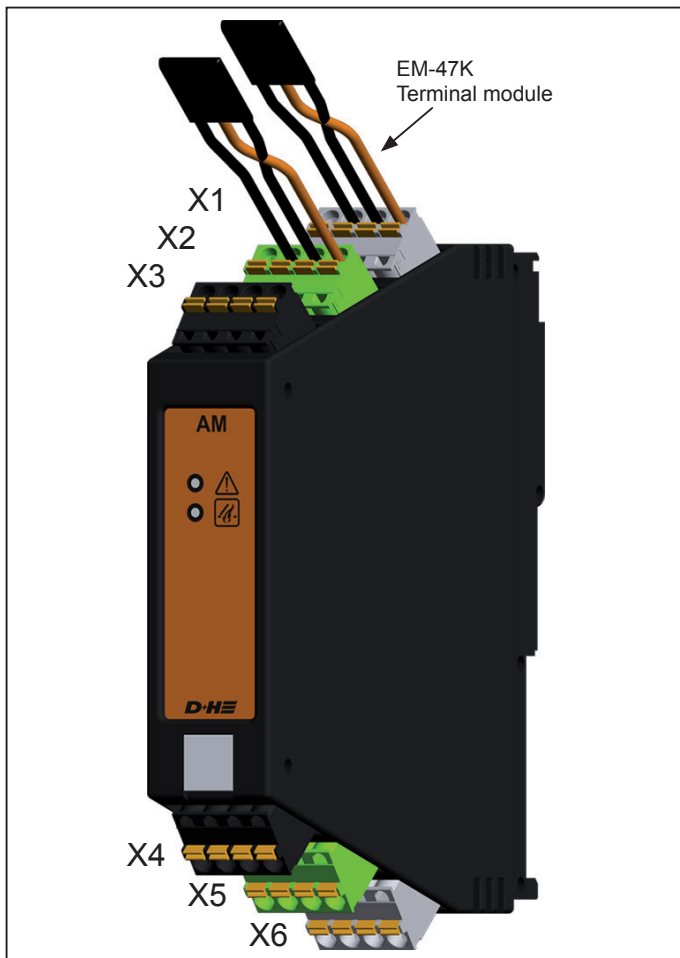

No.	Name	Description
X1.1	P-	Reference potential, max. 10 A (do not connect to -)
X1.2	MOT.b 1	Drive group 1, max. 10 A
X1.3	MOT.a 1	
X1.4	E/HS 1	Monitoring wire / high-speed for actuator group 1
X2.1	P-	Reference potential, max. 10 A (do not connect to -)
X2.2	MOT.b 2	Drive group 2, max. 10 A
X2.3	MOT.a 2	
X2.4	E/HS 2	Monitoring wire / high-speed for actuator group 2
X3.4	ACB.B 1	ACB interface of drive group 1
X3.3	ACB.A 1	
X3.2	ACB.B 2	ACB interface of drive group 2
X3.1	ACB.A 2	
X4.4	SGI 1	Position transmitter for drive group 1 (not yet implemented)
X4.3	-	Reference potential (do not connect to P-)
X4.2	SGI 2	Position transmitter for drive group 2 (not yet implemented)
X4.1	-	Reference potential (do not connect to P-)
X5.4	DO 2.1	Freely configurable digital output 1.1, max. 50 mA / NOT CLOSED signal LT 2
X5.3	-	Reference potential (do not connect to P-)
X5.2	DI 2.1	Freely configurable digital input, 0 to 28 V, active minus or plus / OPEN LT2
X5.1	DI 2.2	Freely configurable digital input, 0 to 28 V, active minus or plus / CLOSED LT 2
X6.4	DO 1.1	Freely configurable digital output 2.1, max. 50 mA / NOT CLOSED signal LT 1
X6.3	-	Reference potential (do not connect to P-)
X6.2	DI 1.1	Freely configurable digital input, 0 to 28 V, active minus or plus / OPEN LT 1
X6.1	DI 1.2	Freely configurable digital input, 0 to 28 V, active minus or plus / CLOSED LT1

Connection – Vent buttons to AM

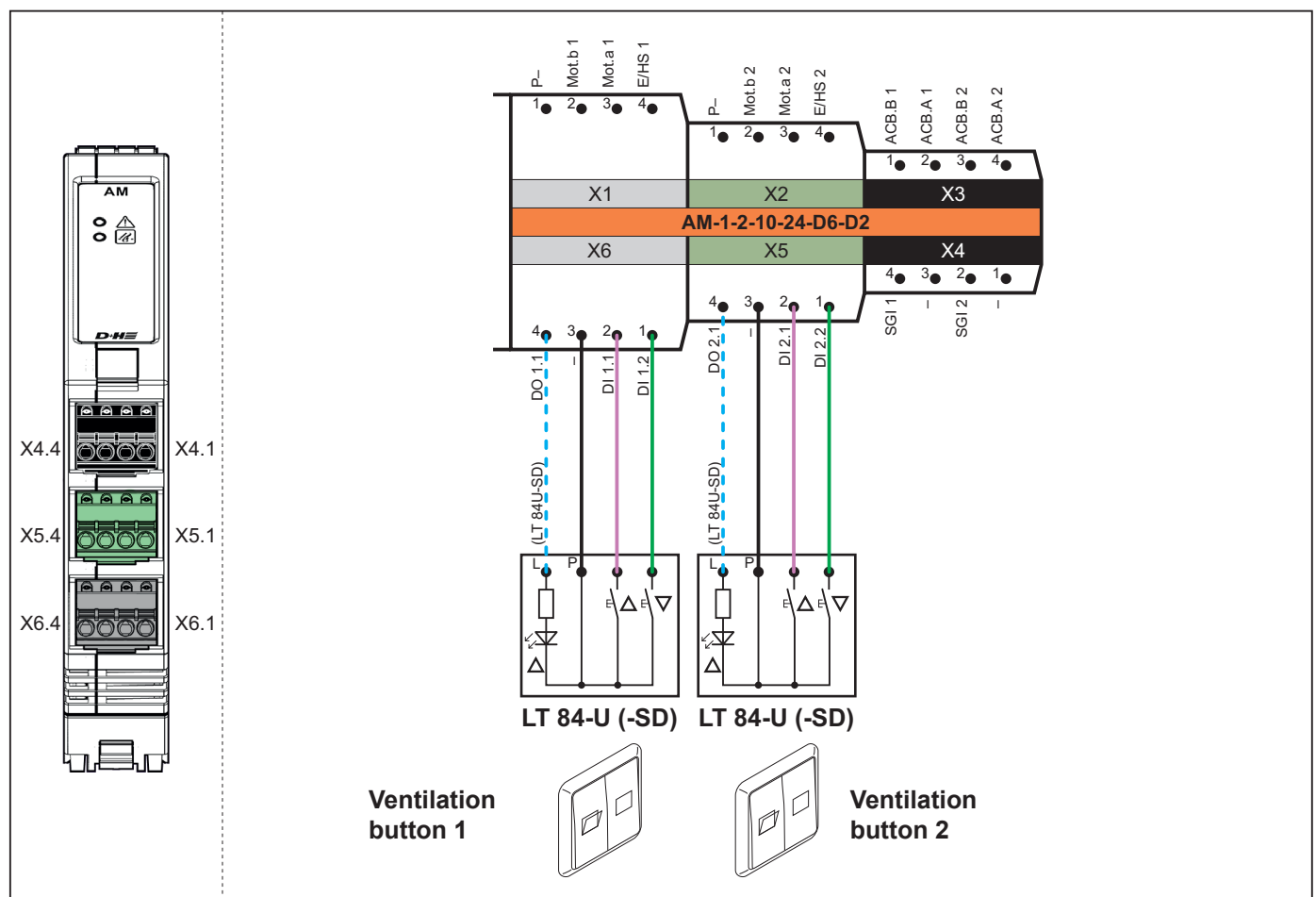

Connection – AM with ACB drives

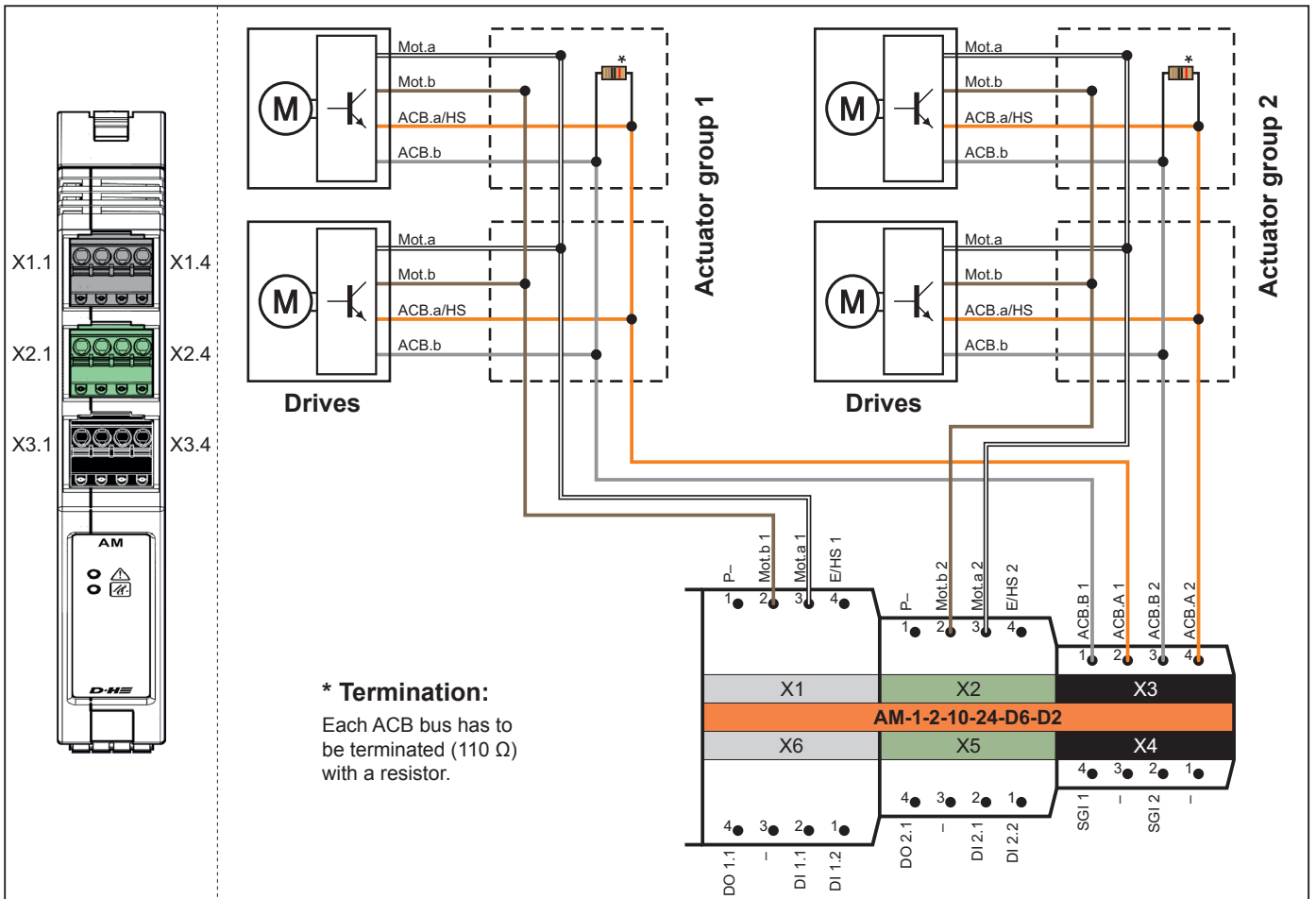

Connection – AM with pole-changing drives

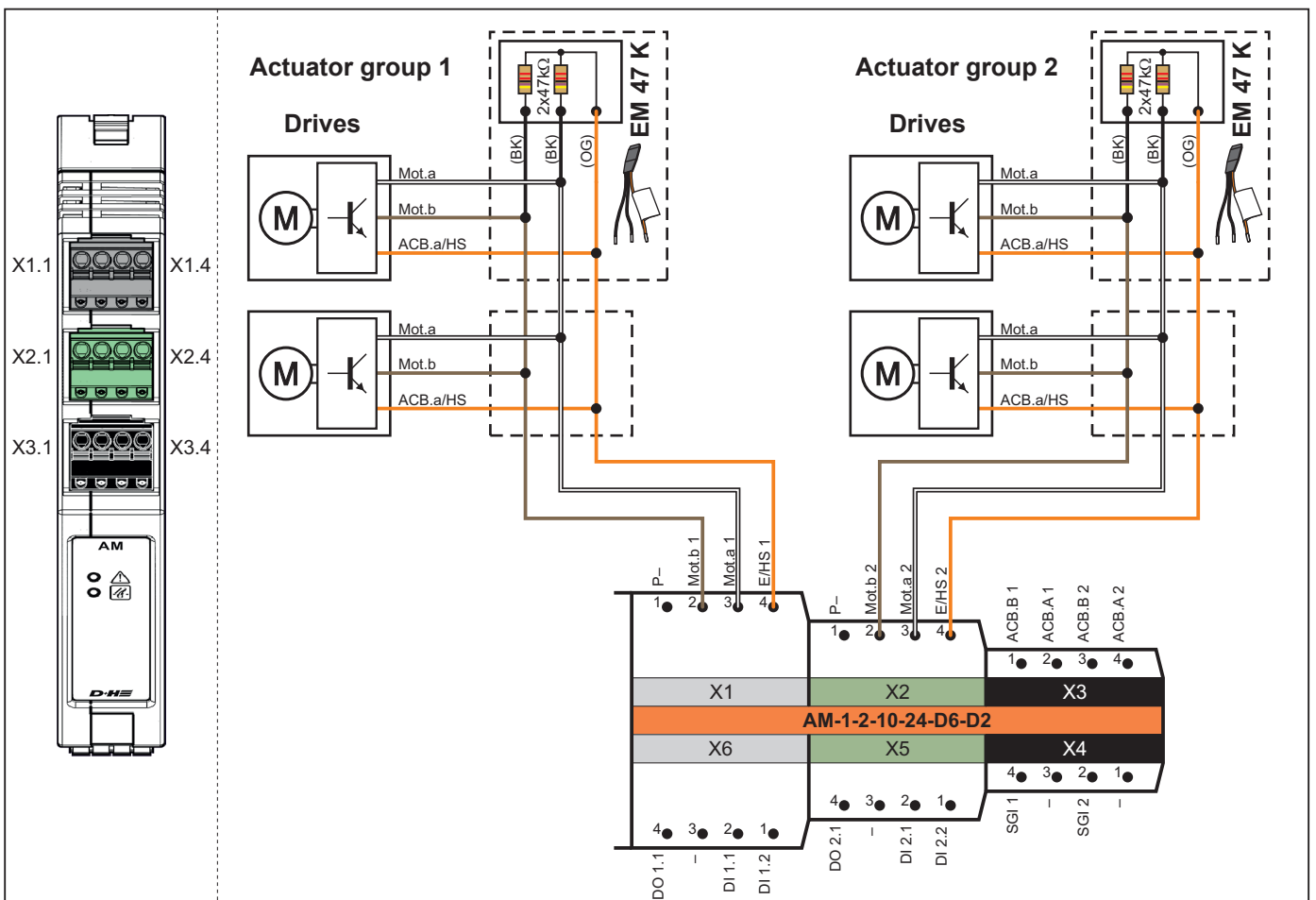

Connection – TMA

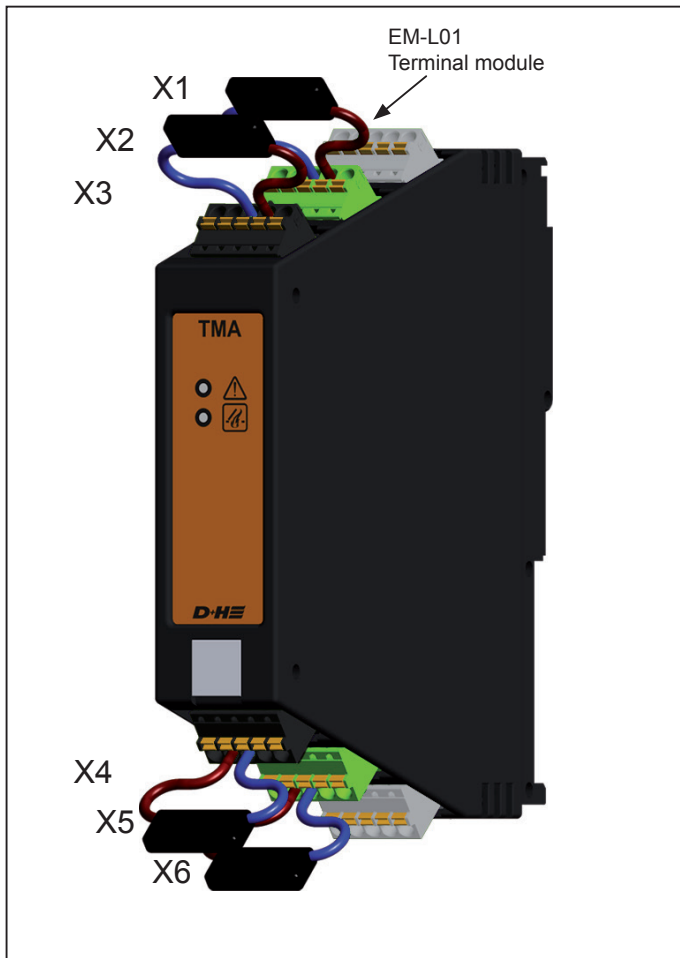

No.	Name	Description (as RM/RT lines)	
X1.1	DO 2.3	No function	RT line 1
X1.2	DO 2.2	No function	
X1.3	-	Reference potential (do not connect to P-)	
X1.4	DO 1.3 (S)	Fault output (RT line 1), max. 50 mA	
X1.5	DO 1.2 (A)	Alarm output (RT line 1), max. 50 mA	
X2.1	DO 1.1 (K)	Monitoring output (RT line 1), max. 50 mA	RT line 1
X2.2	DI 1.1 (Z)	Reset input (RT line 1)	
X2.3	-	Reference potential (do not connect to P-)	
X2.4	LINIE 1 (T)	RT line 1, max. 50 mA	
X2.5	FE	Functional earth	
X3.1	DO 2.1	No function	RM line 1
X3.2	DI 2.1	No function / Reset input fire alarm system	
X3.3	-	Reference potential (do not connect to P-)	
X3.4	LINIE 2 (R)	RM line 1, max. 50 mA	
X3.5	FE	Functional earth	
X4.5	FE	Functional earth	RM line 2
X4.4	LINIE 3 (R)	RM line 2, max. 50 mA	
X4.3	-	Reference potential (do not connect to P-)	
X4.2	DI 3.1	No function	
X4.1	DO 3.1	No function	
X5.5	FE	Functional earth	RT line 2
X5.4	LINIE 4 (T)	RT Line 2	
X5.3	-	Reference potential (do not connect to P-)	
X5.2	DI 4.1 (Z)	Reset input (RT line 2)	
X5.1	DO 4.1 (K)	Monitoring output (RT line 2), max. 50 mA	
X6.5	DO 3.2 (A)	Alarm output (RT line 2), max. 50 mA	RT line 2
X6.4	DO 3.3 (S)	Fault output (RT line 2), max. 50 mA	
X6.3	-	Reference potential (do not connect to P-)	
X6.2	DO 4.2	No function	
X6.1	DO 4.3	No function	

No.	Name	Description (as digital inputs/outputs)
X1.5	DO 1.2 (A)	Freely configurable digital output 1.2, max. 50 mA
X1.4	DO 1.3 (S)	Freely configurable digital output 1.3, max. 50 mA
X1.3	-	Reference potential (do not connect to P-)
X1.2	DO 2.2	Freely configurable digital output 2.2, max. 50 mA
X1.1	DO 2.3	Freely configurable digital output 2.3, max. 50 mA
X2.5	FE	Functional earth
X2.4	LINIE 1 (T)	No function
X2.3	-	Reference potential (do not connect to P-)
X2.2	DI 1.1 (Z)	Freely configurable digital input 1.1, 0 to 28 V, active minus or plus
X2.1	DO 1.1 (K)	Freely configurable digital output 1.1, max. 50 mA
X3.5	FE	Functional earth
X3.4	LINIE 2 (R)	No function
X3.3	-	Reference potential (do not connect to P-)
X3.2	DI 2.1	Freely configurable digital input 2.1, 0 to 28 V, active minus or plus
X3.1	DO 2.1	Freely configurable digital output 2.1, max. 50 mA
X4.5	FE	Functional earth
X4.4	LINIE 3 (R)	No function
X4.3	-	Reference potential (do not connect to P-)
X4.2	DI 3.1	Freely configurable digital input 3.1, 0 to 28 V, active minus or plus
X4.1	DO 3.1	Freely configurable digital output 3.1, max. 50 mA
X5.5	FE	Functional earth
X5.4	LINIE 4 (T)	No function
X5.3	-	Reference potential (do not connect to P-)
X5.2	DI 4.1 (Z)	Freely configurable digital input 4.1, 0 to 28 V, active minus or plus
X5.1	DO 4.1 (K)	Freely configurable digital output 4.1, max. 50 mA
X6.5	DO 3.2 (A)	Freely configurable digital output 3.2, max. 50 mA
X6.4	DO 3.3 (S)	Freely configurable digital output 3.3, max. 50 mA
X6.3	-	Reference potential (do not connect to P-)
X6.2	DO 4.2	Freely configurable digital output 4.2, max. 50 mA
X6.1	DO 4.3	Freely configurable digital output 4.3, max. 50 mA

Connection – TMA (2 lines)

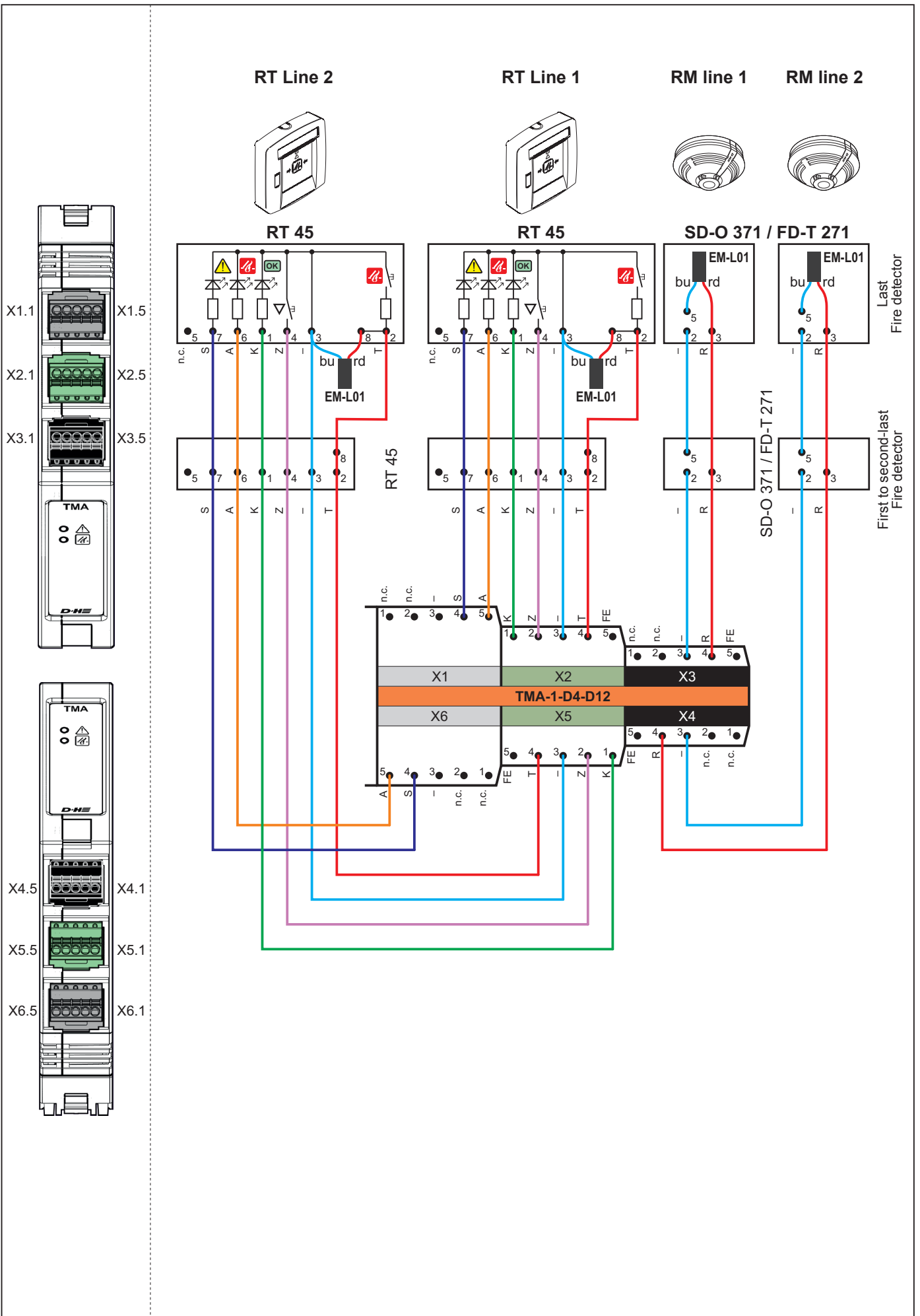

Connection – TMA parallel connection RT

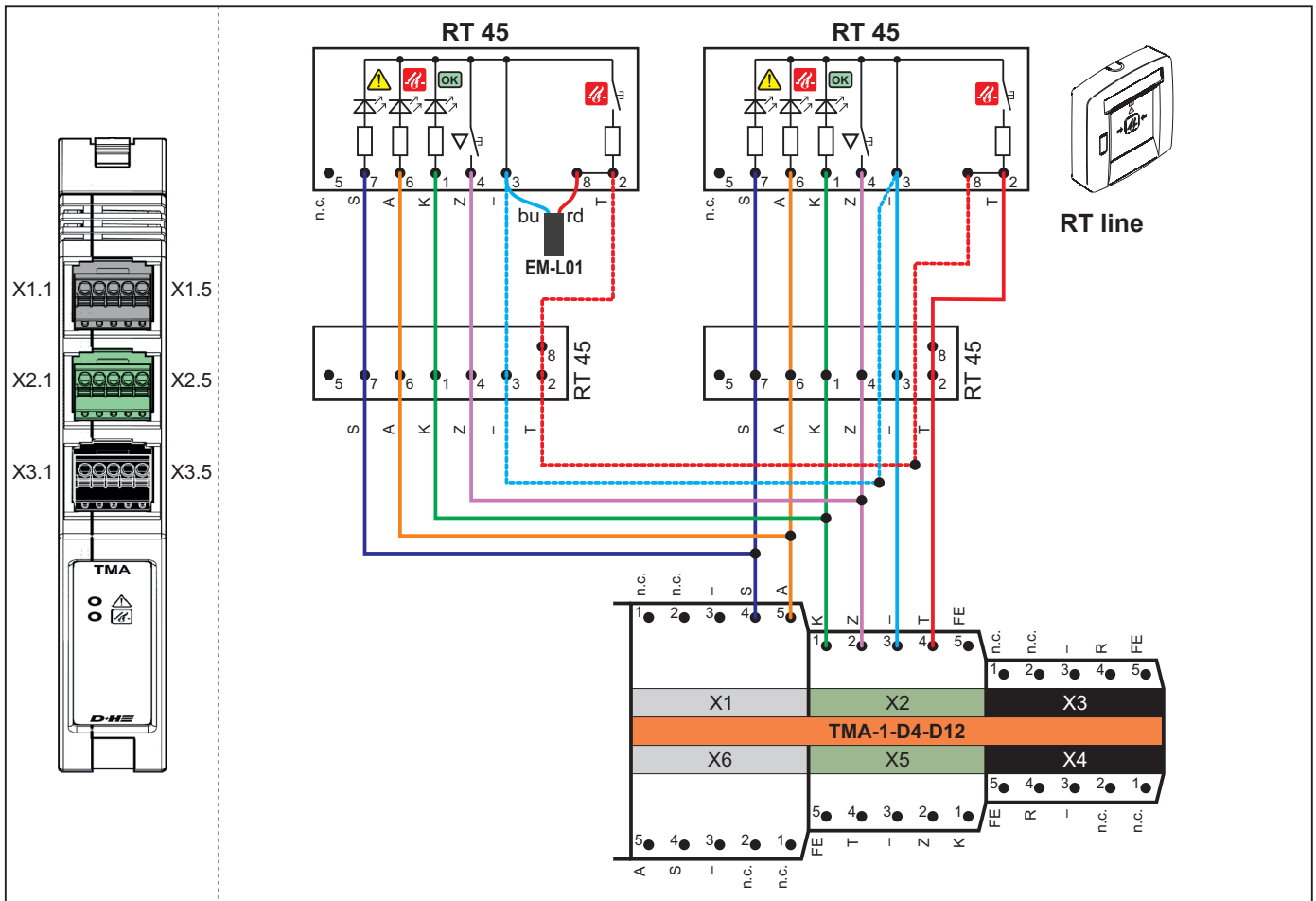

Connection – TMA to fire alarm system (FAS)

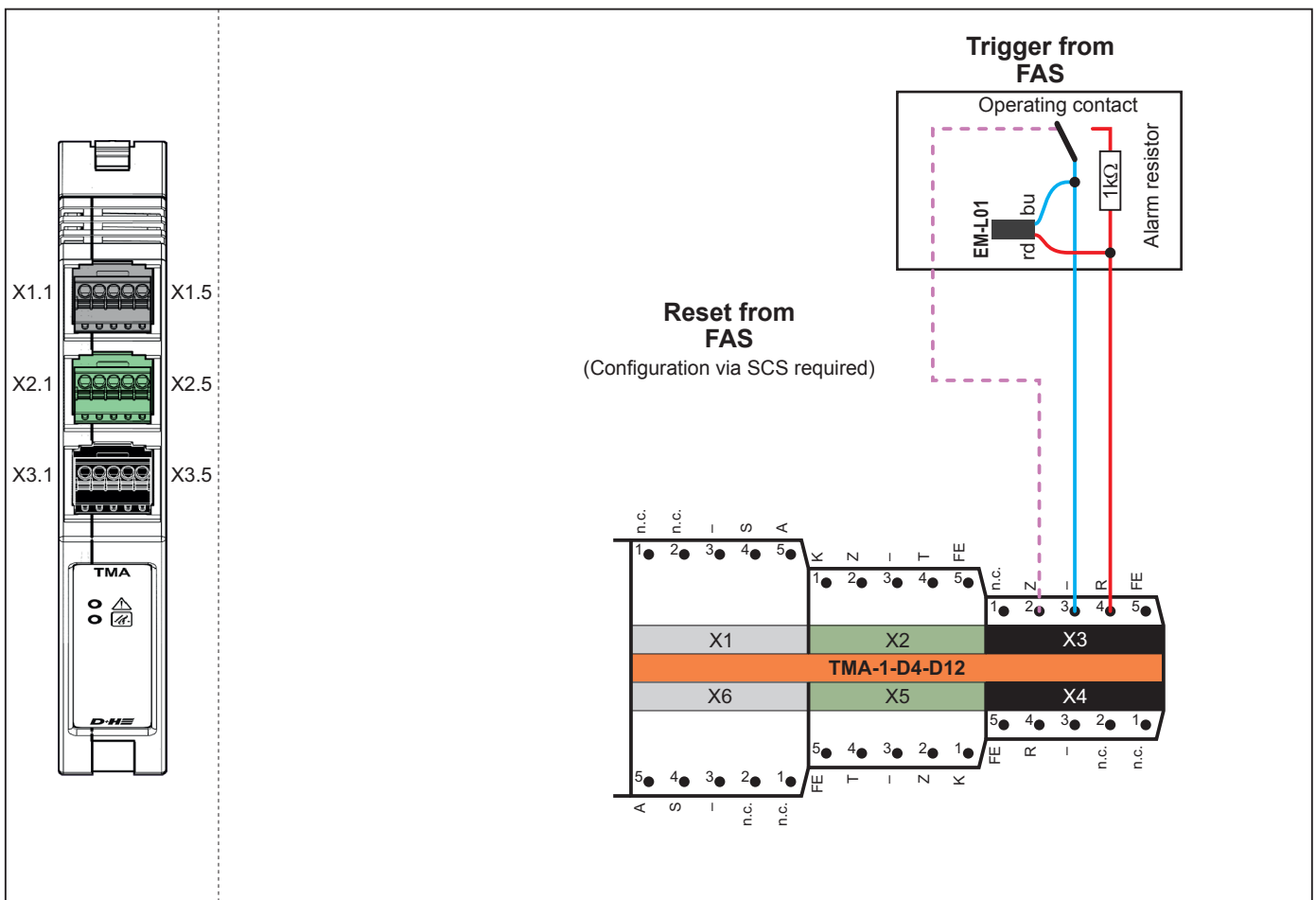

Description of the inputs and outputs

Designation	Description
-	Reference potential / negative: used as the reference potential for external peripherals (e.g. SHEV operation panel or LT). May not be connected to P-. The reference potentials of more than one power supply module may not be connected together.
ACB.A x / ACB.B x MOT.a x / MOT.b x	Group (ACB): used for the connection of bus-capable drives. ACB.A x and ACB.B x are necessary for communication with the drives. MOT.a x and MOT.b x are necessary for supplying the connected drives. The maximum output current of the supply is 10 A. The supply is permanently short-circuit resistant and the fuse used is self-resetting.
ACN D+ / ACN D- Shield	AdComNet connection: used for interconnecting more than one CPS-M1. Currently, ACN-CM501, ACN-IO501, ACN-BI501-USB and ACN-GW501-MRTU cannot be connected with the CPS-M1. If this connection is not used, it must nevertheless be terminated with a resistor (110 Ohm).
BATT+ / BATT-	Battery connection: may only be used for connecting the secondary power supply (battery).
COM x / NC x / NO x	Isolated output: used for the triggering of external systems. The maximum contact current is 1 A. The minimum contact current to ensure permanent safe operation is 10 mA. The maximum contact voltage is 35 V DC. The contact is not suitable for switching 230 V AC. The output can be supplied with emergency power. This is to be taken into consideration in the battery capacity calculation.
DI x.x	Digital input: used for the evaluation of switch signals. The input voltage range is 0 V DC to 28 V DC. The pull-up resistor for the evaluation of an active negative signal is integrated. The pull-down resistor for the detection of an active positive signal is integrated. The switching contact is briefly (< 100 ms) loaded with 16 mA. The input DI 1.1 of the controller module cannot currently be used.
DO x.x	Digital output: used for the triggering of displays or relays. The output voltage range of an activated output is 17 V DC to 25 V DC. The output voltage range applies for a maximum output current of 50 mA. The connection is permanently short-circuit resistant and the fuse used is self-resetting. If the output is deactivated, the output is open / has a high resistance. Active negative inputs cannot be switched using the output. The output can be supplied with emergency power. This is to be taken into consideration in the battery capacity calculation.
FE	Functional earth: can be used as the cable shielding connection when connecting a smoke detector line. May only be used as a cable shielding connection.
LINE / RT x	Line connection: used for connecting a smoke detector line or an SHEV operation panel line. Furthermore, external systems (e.g. fire detectors) can be connected.
LINE / RM x	A maximum of 30 smoke detectors or 10 SHEV operation panels can be connected. The connection is permanently short-circuit resistant and the fuse used is self-resetting. Cable monitoring is performed via the EM-L01.
MOT.A x / MOT.B x E/HS	Group (polarity change): used for the connection of conventional pole-changing drives. MOT.A x and MOT.B x are necessary for the supply and for controlling the direction. The maximum output current of the supply is 10 A. The supply is permanently short-circuit resistant and the fuse used is self-resetting. E/HS is used for cable monitoring and for triggering the high-speed function.
n.c.	The terminal is not connected.
N+	Operating voltage not supplied with emergency power: used for the supply of external peripherals. The output voltage range is 22 V DC to 24 V DC. The maximum output current is 440 mA.
P-	Group reference potential / group negative: used as the reference potential for external drives (e.g. spring return actuators). May not be connected to -. The group reference potentials of more than one power supply module may not be connected together.
+	Operating voltage supplied with emergency power: used for the supply of external peripherals. The current consumption of the connected peripherals must be taken into consideration in the battery capacity calculation. The output voltage range is 19 V DC to 27 V DC. The maximum output current is 440 mA.
SGI x	This function has not yet been implemented.
SNT+ / SNT-	Mains power connection: may only be used for connecting the primary power supply (power pack).
TCSU1	Temperature sensor connection: may only be used for connecting the TCSU1-RJ12. The maximum cable length to ensure permanent safe operation is 2 m.
TP-C1	Touch panel connection: may only be used for connecting the TP-C1-35-RJ12.

Commissioning and configuration with the SCS software

The D+H Service and Configuration Suite (SCS) is used for commissioning and programming.

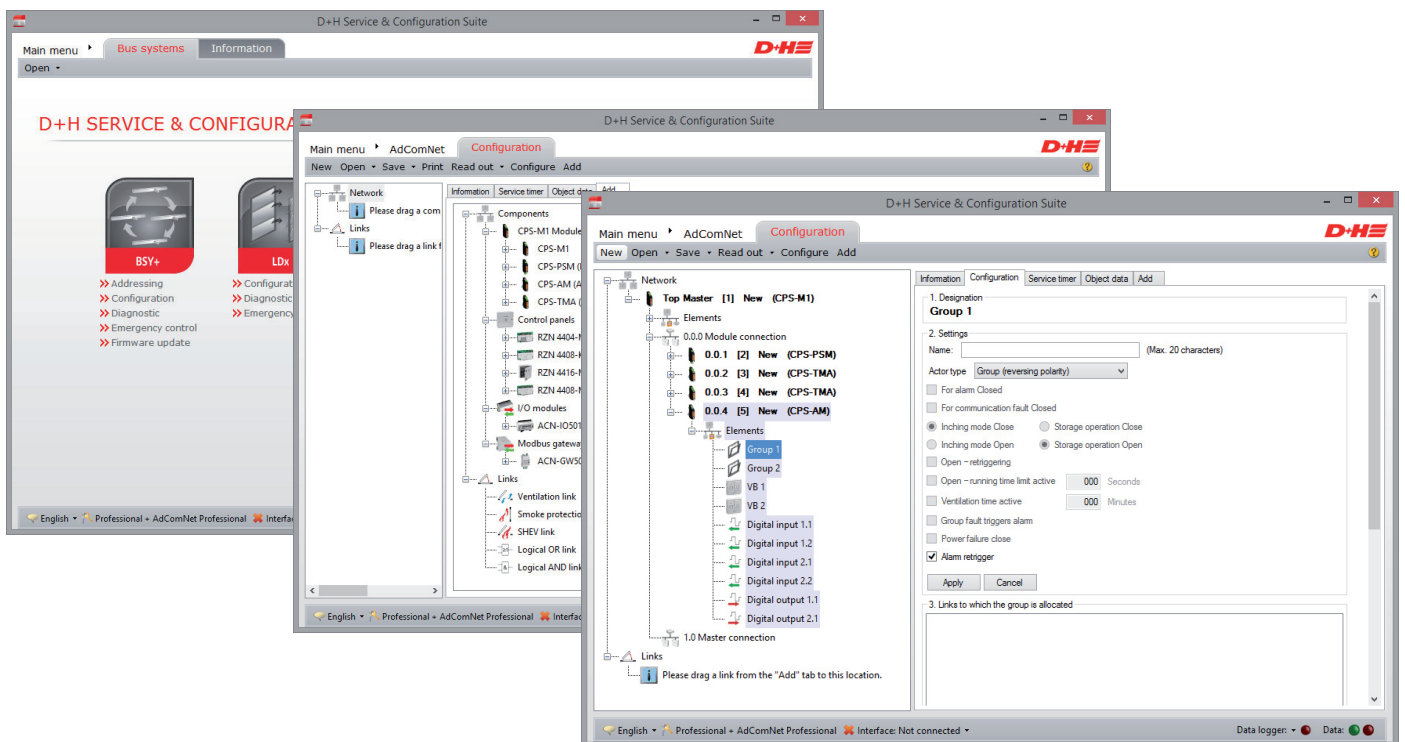

1. Designation
Digital input 1.2

2. Settings
Designation: (max. 20 characters)

Functionality selection: (internal pull-down resistor)

- Active minus (internal)
- Inverted

Apply Cancel

3. Links to which the digital input is allocated

SHEV-link-2

1. Designation
Isolated output 1

2. Settings
Designation: (max. 20 characters)

Functionality selection: emergency power

- Output inverted

Apply Cancel

3. Links to which the digital output is allocated

1. Designation
Group 1

2. Settings
Name: (Max. 20 characters)

Actor type: (Group (ACB))

- For alarm Closed
- For communication fault Closed
- Inching mode Close Storage operation Close
- Inching mode Open Storage operation Open
- Open - retrigging
- Open - running time limit active 000 Seconds
- Ventilation time active 000 Minutes
- Group fault triggers alarm
- Power failure close
- Alarm retrigger

Apply Cancel

3. ACB
Readout Addressing

4. Links to which the group is allocated

Standard configurations

Controller Module (CM)

The isolated outputs from Controller Module are pre-configured by all standard control panels. The terminal X1 is for general fault and the terminal X2 for general alarm signals. The digital inputs X6.2 and X6.3 are pre-configured for general open- and general close-signals.

Actuator modules and trigger modules (AM / TMA)

Screenshots from SCS-Tool for the standard pre-configured actuator modules and trigger modules.

AM:

1. Designation
Group 1 • Gruppe 1

2. Settings
Name: (Max. 20 characters)
Actor type: Arrest while stopped

For alarm Closed
 For communication fault Closed

Inching mode Close Storage operation Close
 Inching mode Open Storage operation Open

Open -retriggering
 Open -running time limit active Seconds
 Ventilation time active Minutes
 Group fault triggers alarm
 Power failure close
 Alarm retrigger

TMA:

1. Designation
Line 1

2. Settings
Designation: (max. 20 characters)
 RM can only be locally reset
 Line fault triggers alarm

3. Links to which the line is allocated

Standard classification CPS-M1-XXX-XXXX

Trigger Module / Trigger Line >> Actuator Module / Actuator Group

All ventilation button inputs are pre-configured with the same module actuator group with the same color.

31.700.10 CPS-M1-020-0202	Trigger Module 1 Trigger Line1 >> Actuator Module 1 Actuator Group 1, Trigger Module 1 Trigger Line2 >> Actuator Module 1 Actuator Group 2
31.700.15 CPS-M1-020-0204	Trigger Module 1 Trigger Line1 >> Actuator Module 1 Actuator Group 1+2, Trigger Module 1 Trigger Line2 >> Actuator Module 2 Actuator Group 1+2
31.700.20 CPS-M1-020-0404	Trigger Module 1 Trigger Line1 >> Actuator Module 1 Actuator Group 1, Trigger Module 1 Trigger Line2 >> Actuator Module 1 Actuator Group 2, Trigger Module 2 Trigger Line1 >> Actuator Module 2 Actuator Group 1, Trigger Module 2 Trigger Line2 >> Actuator Module 2 Actuator Group 2
31.700.25 CPS-M1-020-0606	Trigger Module 1 Trigger Line1 >> Actuator Module 1 Actuator Group 1, Trigger Module 1 Trigger Line2 >> Actuator Module 1 Actuator Group 2, Trigger Module 2 Trigger Line1 >> Actuator Module 2 Actuator Group 1, Trigger Module 2 Trigger Line2 >> Actuator Module 2 Actuator Group 2, Trigger Module 3 Trigger Line1 >> Actuator Module 3 Actuator Group 1, Trigger Module 3 Trigger Line2 >> Actuator Module 3 Actuator Group 2
31.700.30 CPS-M1-040-0204	Trigger Module 1 Trigger Line1 >> Actuator Module 1 Actuator Group 1+2, Trigger Module 1 Trigger Line2 >> Actuator Module 1 Actuator Group 1+2
31.700.35 CPS-M1-040-0206	Trigger Module 1 Trigger Line1 >> Actuator Module 1 Actuator Group 1+2, Trigger Module 1 Trigger Line2 >> Actuator Module 2 Actuator Group 1, Trigger Module 2 Trigger Line1 >> Actuator Module 2 Actuator Group 2, Trigger Module 2 Trigger Line2 >> Actuator Module 3 Actuator Group 1+2
31.700.40 CPS-M1-040-0404	Trigger Module 1 Trigger Line1 >> Actuator Module 1 Actuator Group 1, Trigger Module 1 Trigger Line2 >> Actuator Module 1 Actuator Group 2, Trigger Module 2 Trigger Line1 >> Actuator Module 2 Actuator Group 1, Trigger Module 2 Trigger Line2 >> Actuator Module 2 Actuator Group 2
31.700.45 CPS-M1-040-0406	Trigger Module 1 Trigger Line1 >> Actuator Module 1 Actuator Group 1+2, Trigger Module 1 Trigger Line2 >> Actuator Module 2 Actuator Group 1+2, Trigger Module 2 Trigger Line1 >> Actuator Module 3 Actuator Group 1, Trigger Module 2 Trigger Line2 >> Actuator Module 3 Actuator Group 2
31.700.50 CPS-M1-040-0606	Trigger Module 1 Trigger Line1 >> Actuator Module 1 Actuator Group 1, Trigger Module 1 Trigger Line2 >> Actuator Module 1 Actuator Group 2, Trigger Module 2 Trigger Line1 >> Actuator Module 2 Actuator Group 1, Trigger Module 2 Trigger Line2 >> Actuator Module 2 Actuator Group 2, Trigger Module 3 Trigger Line1 >> Actuator Module 3 Actuator Group 1, Trigger Module 3 Trigger Line2 >> Actuator Module 3 Actuator Group 2
31.700.55 CPS-M1-060-0206	Trigger Module 1 Trigger Line1 >> Actuator Module 1 Actuator Group 1+2, Trigger Module 1 Trigger Line1 >> Actuator Module 2 Actuator Group 1, Trigger Module 1 Trigger Line2 >> Actuator Module 2 Actuator Group 2, Trigger Module 1 Trigger Line2 >> Actuator Module 3 Actuator Group 1+2
31.700.60 CPS-M1-060-0208	Trigger Module 1 Trigger Line1 >> Actuator Module 1 Actuator Group 1+2, Trigger Module 1 Trigger Line1 >> Actuator Module 2 Actuator Group 1+2, Trigger Module 1 Trigger Line2 >> Actuator Module 3 Actuator Group 1+2, Trigger Module 1 Trigger Line2 >> Actuator Module 4 Actuator Group 1+2
31.700.65 CPS-M1-060-0210	Trigger Module 1 Trigger Line1 >> Actuator Module 1 Actuator Group 1+2, Trigger Module 1 Trigger Line1 >> Actuator Module 3 Actuator Group 1, Trigger Module 1 Trigger Line2 >> Actuator Module 3 Actuator Group 2, Trigger Module 1 Trigger Line2 >> Actuator Module 4 Actuator Group 1+2, Trigger Module 1 Trigger Line2 >> Actuator Module 5 Actuator Group 1+2
31.700.70 CPS-M1-060-0406	Trigger Module 1 Trigger Line1 >> Actuator Module 1 Actuator Group 1+2, Trigger Module 1 Trigger Line2 >> Actuator Module 2 Actuator Group 1+2, Trigger Module 2 Trigger Line1 >> Actuator Module 3 Actuator Group 1, Trigger Module 2 Trigger Line2 >> Actuator Module 3 Actuator Group 2
31.700.75 CPS-M1-060-0408	Trigger Module 1 Trigger Line1 >> Actuator Module 1 Actuator Group 1+2, Trigger Module 1 Trigger Line2 >> Actuator Module 2 Actuator Group 1+2, Trigger Module 2 Trigger Line1 >> Actuator Module 3 Actuator Group 1+2, Trigger Module 2 Trigger Line2 >> Actuator Module 4 Actuator Group 1+2
31.700.80 CPS-M1-060-0410	Trigger Module 1 Trigger Line1 >> Actuator Module 1 Actuator Group 1+2, Trigger Module 1 Trigger Line1 >> Actuator Module 2 Actuator Group 1, Trigger Module 1 Trigger Line2 >> Actuator Module 2 Actuator Group 2, Trigger Module 1 Trigger Line2 >> Actuator Module 3 Actuator Group 1+2, Trigger Module 2 Trigger Line1 >> Actuator Module 4 Actuator Group 1+2, Trigger Module 2 Trigger Line2 >> Actuator Module 5 Actuator Group 1+2

Standard configurations (continuation)

Standard classification CPS-M1-XXX-XXXX

Trigger Module / Trigger Line >> Actuator Module / Actuator Group

All ventilation button inputs are pre-configured with the same module actuator group with the same color.

31.700.85 CPS-M1-080-0208	Trigger Module 1 Trigger Line1 >> Actuator Module 1 Actuator Group 1+2,
	Trigger Module 1 Trigger Line1 >> Actuator Module 2 Actuator Group 1+2,
	Trigger Module 1 Trigger Line2 >> Actuator Module 3 Actuator Group 1+2,
	Trigger Module 1 Trigger Line2 >> Actuator Module 4 Actuator Group 1+2,
31.700.90 CPS-M1-080-0210	Trigger Module 1 Trigger Line1 >> Actuator Module 1 Actuator Group 1+2,
	Trigger Module 1 Trigger Line1 >> Actuator Module 2 Actuator Group 1+2,
	Trigger Module 1 Trigger Line2 >> Actuator Module 3 Actuator Group 1,
	Trigger Module 1 Trigger Line2 >> Actuator Module 4 Actuator Group 1+2,
31.700.95 CPS-M1-080-0408	Trigger Module 1 Trigger Line1 >> Actuator Module 1 Actuator Group 1+2,
	Trigger Module 1 Trigger Line2 >> Actuator Module 2 Actuator Group 1+2,
	Trigger Module 2 Trigger Line1 >> Actuator Module 3 Actuator Group 1+2,
	Trigger Module 2 Trigger Line2 >> Actuator Module 4 Actuator Group 1+2,
31.701.00 CPS-M1-080-0410	Trigger Module 1 Trigger Line1 >> Actuator Module 1 Actuator Group 1+2,
	Trigger Module 1 Trigger Line1 >> Actuator Module 2 Actuator Group 1,
	Trigger Module 1 Trigger Line2 >> Actuator Module 2 Actuator Group 2,
	Trigger Module 1 Trigger Line2 >> Actuator Module 3 Actuator Group 1+2,
31.701.05 CPS-M1-080-0608	Trigger Module 2 Trigger Line1 >> Actuator Module 4 Actuator Group 1+2,
	Trigger Module 2 Trigger Line2 >> Actuator Module 5 Actuator Group 1+2,
	Trigger Module 1 Trigger Line1 >> Actuator Module 1 Actuator Group 1+2,
	Trigger Module 1 Trigger Line2 >> Actuator Module 2 Actuator Group 1+2,
31.701.10 CPS-M1-080-0610	Trigger Module 2 Trigger Line1 >> Actuator Module 2 Actuator Group 1,
	Trigger Module 2 Trigger Line2 >> Actuator Module 3 Actuator Group 2,
	Trigger Module 3 Trigger Line1 >> Actuator Module 4 Actuator Group 1,
	Trigger Module 3 Trigger Line2 >> Actuator Module 5 Actuator Group 2,
31.701.15 CPS-M1-080-0808	Trigger Module 1 Trigger Line1 >> Actuator Module 1 Actuator Group 1+2,
	Trigger Module 1 Trigger Line2 >> Actuator Module 2 Actuator Group 1+2,
	Trigger Module 2 Trigger Line1 >> Actuator Module 2 Actuator Group 1,
	Trigger Module 2 Trigger Line2 >> Actuator Module 2 Actuator Group 2,
31.701.20 CPS-M1-080-0810	Trigger Module 3 Trigger Line1 >> Actuator Module 3 Actuator Group 1,
	Trigger Module 3 Trigger Line2 >> Actuator Module 3 Actuator Group 1,
	Trigger Module 4 Trigger Line1 >> Actuator Module 4 Actuator Group 1,
	Trigger Module 4 Trigger Line2 >> Actuator Module 4 Actuator Group 2,
31.701.25 CPS-M1-080-1010	Trigger Module 5 Trigger Line1 >> Actuator Module 5 Actuator Group 1,
	Trigger Module 5 Trigger Line2 >> Actuator Module 5 Actuator Group 2,
	Trigger Module 1 Trigger Line1 >> Actuator Module 1 Actuator Group 1,
	Trigger Module 1 Trigger Line2 >> Actuator Module 1 Actuator Group 2,
31.701.35 CPS-M1-080-0216	Trigger Module 2 Trigger Line1 >> Actuator Module 2 Actuator Group 1,
	Trigger Module 2 Trigger Line2 >> Actuator Module 2 Actuator Group 2,
	Trigger Module 3 Trigger Line1 >> Actuator Module 3 Actuator Group 1,
	Trigger Module 3 Trigger Line2 >> Actuator Module 3 Actuator Group 2,
	Trigger Module 4 Trigger Line1 >> Actuator Module 4 Actuator Group 1,
	Trigger Module 4 Trigger Line2 >> Actuator Module 4 Actuator Group 2,
	Trigger Module 5 Trigger Line1 >> Actuator Module 5 Actuator Group 1,
	Trigger Module 5 Trigger Line2 >> Actuator Module 5 Actuator Group 2,
	Trigger Module 1 Trigger Line1 >> Actuator Module 1 Actuator Group 1+2,
	Trigger Module 1 Trigger Line1 >> Actuator Module 2 Actuator Group 1+2,
	Trigger Module 1 Trigger Line1 >> Actuator Module 3 Actuator Group 1+2,
	Trigger Module 1 Trigger Line1 >> Actuator Module 4 Actuator Group 1+2,
	Trigger Module 1 Trigger Line2 >> Actuator Module 5 Actuator Group 1+2,
	Trigger Module 1 Trigger Line2 >> Actuator Module 6 Actuator Group 1+2,
	Trigger Module 1 Trigger Line2 >> Actuator Module 7 Actuator Group 1+2,
	Trigger Module 1 Trigger Line2 >> Actuator Module 8 Actuator Group 1+2,

Description of the software functions

Designation	Connection	Description
Digital output	Output inverted	The output issues the status of the link inverted.
	Functionality selection	SHEV link: Alarm / Alarm Reset / Alarm Pulse / Fault / Not Closed Ventilation link: Not Closed / LT Open forwarding / LT Closed forwarding
	Supplied with emergency power	The output is also triggered in the event of a mains outage. An additional 0.072 Ah is to be taken into consideration in the battery capacity calculation. Furthermore, the current consumption of the connected peripherals is to be taken into consideration.
	Functionality	SHEV link: Alarm / Alarm Pulse / Alarm Reset and RT Closed / Alarm and Alarm Reset with RT Closed / Fault Ventilation link: LT Open / LT Closed / LT Stop / LT Open pulse / LT Closed pulse / LT Open and Closed pulse / LT Closed and Open pulse / LT Open pulse and Closed pulse
Digital input	Inverted	The status of the input is forwarded to the link inverted.
	Active negative	The input is activated if switched to -.
	Active positive	The input is activated if switched to P+ or N+.
Group	Actuator type	The group is used for triggering ACB drives or pole-changing drives. The type used must be selected for each group.
	Alarm re-clocking	The group will be triggered every 2 minutes for 30 minutes in the event of an alarm. This function is a requirement of VdS 2581.
	Open – running time limit	The group moves in the OPEN direction for the set time if the ventilation button is switched to the OPEN direction.
	Open – retriggering	The group once more moves in the OPEN direction for the set time if the ventilation button is again switched to the OPEN direction.
	For alarm Closed	The group moves in the CLOSED direction if the SHEV link to which the group is assigned is triggered.
	For communication fault Closed	The group moves in the CLOSED direction if a communication fault occurs within a link to which the group is assigned.
	Group fault triggers alarm	In the event of a group fault (e.g. a monitoring cable is interrupted or an addressed ACB drive is not available), the SHEV link to which the group is assigned is triggered.
	Ventilation time active	The group automatically moves in the CLOSED direction upon expiry of the set ventilation time.
	Mains outage CLOSED	The group automatically moves in the CLOSED direction in the event of a mains outage. Only the control panel groups move in the CLOSED direction in the event of a mains outage. Groups in the same link belonging to another CPS-M are not affected by this.
	Storage operation OPEN	The group moves in the OPEN direction when a ventilation button of the ventilation link is pressed once.
	Storage operation CLOSED	The group moves in the CLOSED direction when a ventilation button of the ventilation link is pressed once.
	Stop-hold function	The supply cables MOT.A x and MOT.B x are short-circuited in the Stop status. A short circuit between these two cables can no longer be recognized as being a fault in this status.
	Button operation OPEN	The group moves in the OPEN direction for as long as the ventilation button of the ventilation link is pressed.
	Button operation CLOSED	The group moves in the CLOSED direction for as long as a ventilation button of the ventilation link is pressed.
Line	Line fault triggers alarm	In the event of a line fault (e.g. an interrupted cable), the SHEV link to which the line is assigned is triggered.
	Smoke detector can only be locally reset	A smoke detector alarm cannot be reset by pressing the "SHEV CLOSED" button on the SHEV button panel. It is possible to reset the alarm via the touch panel.
Isolated output	Output inverted	The output issues the status of the link inverted.
	Functionality selection	SHEV link: Alarm / Alarm Reset / Alarm Pulse / Fault / Not Closed Ventilation link: Not Closed / LT Open forwarding / LT Closed forwarding
	Supplied with emergency power	The output is also triggered in the event of a mains outage. This must be taken into consideration in the battery capacity calculation.

Operation - Touch panel (optional)



Start screen

- Displays the overall status of the control panel



Settings

- Setting the display language

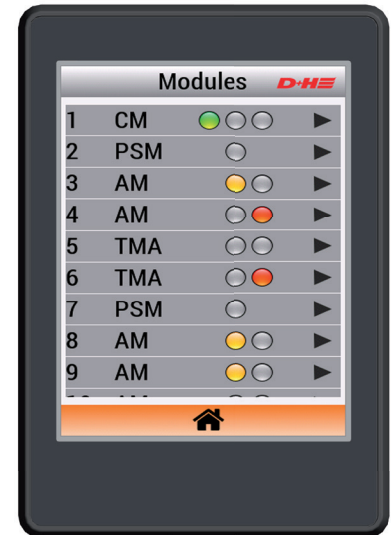

Modules

- Overview of all modules used
- Display of the respective statuses similar to the LEDs on the respective module



CM - Control module

- Display of the module status
- Display of the status of the inputs and outputs

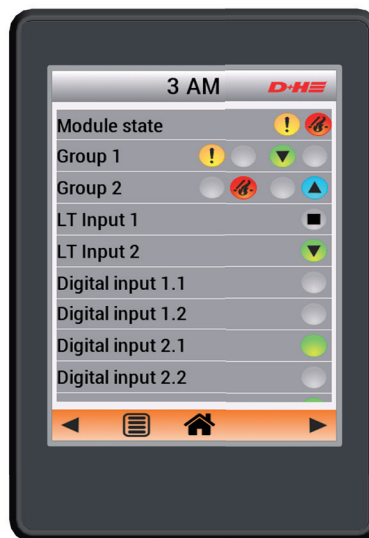

AM - Actuator module

- Display of the module status
- Status display of the groups
- Status display of the inputs and outputs

TMA - Trigger module

- Display of the module status
- Status display of the lines
- Switch on and off, and resetting the lines
- Status display of the inputs and outputs

Operation - Daily ventilation

Ventilation button or SHEV button with RT 45-LT ventilation function required.

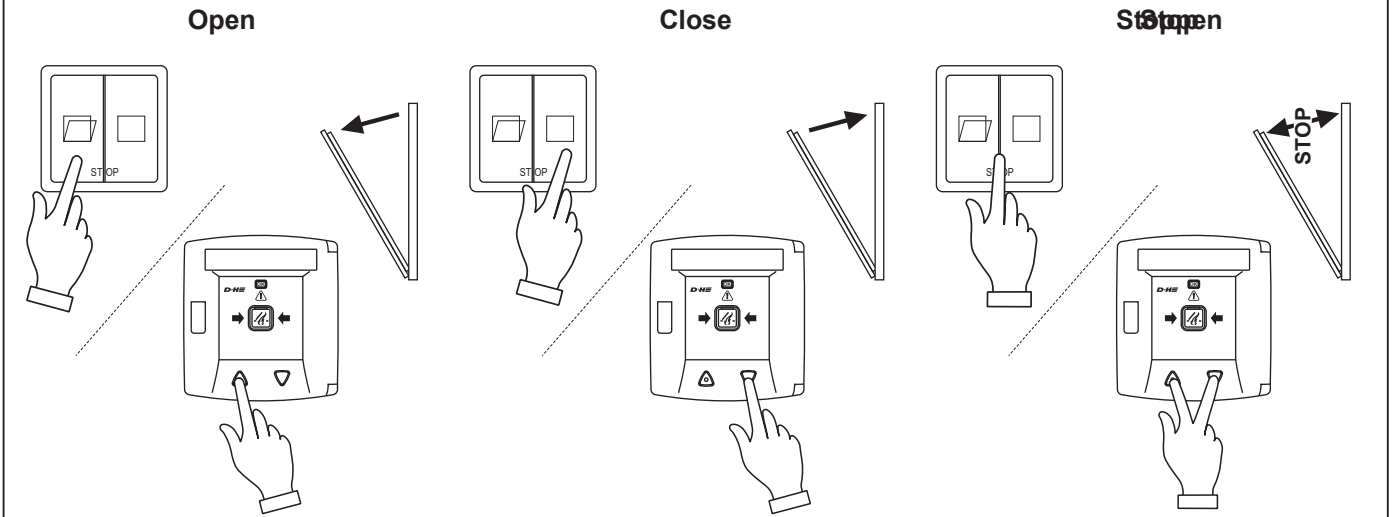

Operation - Weather automation

With connected wind or rain detector.

When the corresponding sensor is triggered, the control panel group is closed. In case of an SHEV alarm, the system also starts in wind or rain.

Do not ventilate using the smoke vent button, as otherwise there is a risk of wind or water damage.

If gap ventilation is desired in bad weather, the weather automation can be switched off using an **optional automatic switch**.

If **no automatic switch** is present, **gap ventilation is not possible in poor weather**. If the weather automation is switched on, the system closes in case of wind or rain.

It does **not** open again automatically after the wind or rain stops. Opening the system for ventilation using the ventilation button.

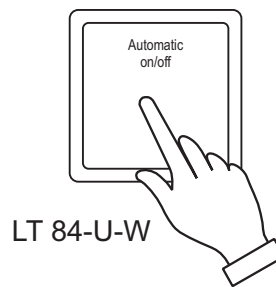

Operation - SHEV



Safety system, protects human life and real property value!
Function check once a year by a specialist company authorised by the manufacturer.

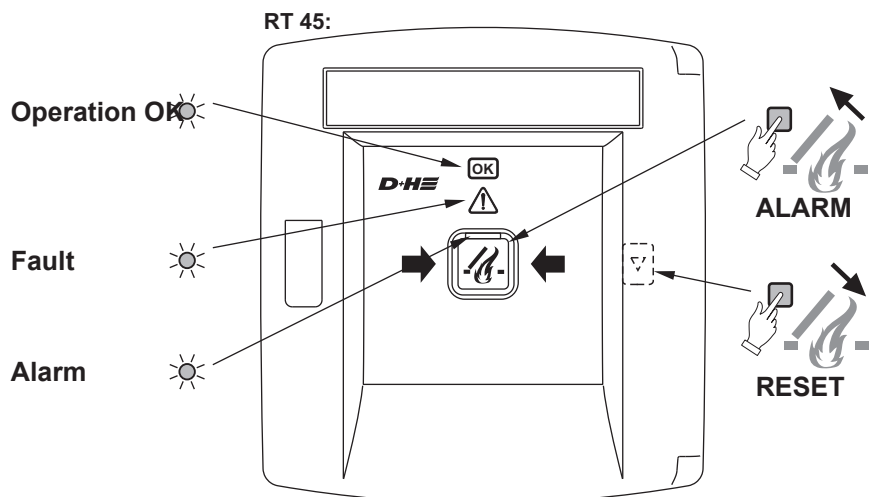

Operation - Trigger on alarm

Manual opening with smoke vent button

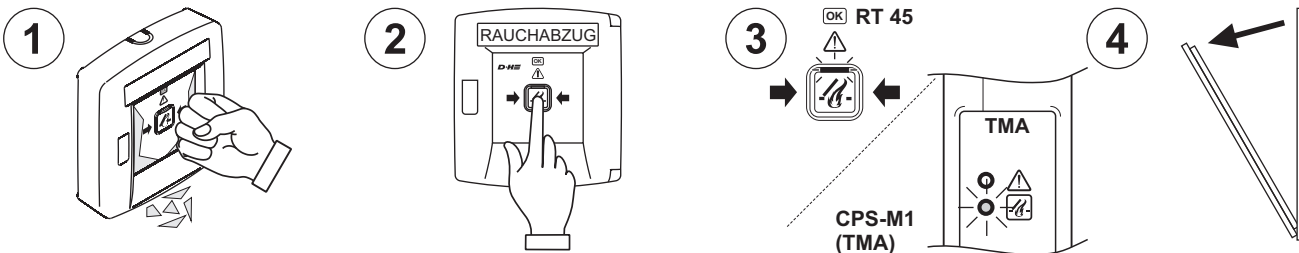

Automatic opening with fire detector

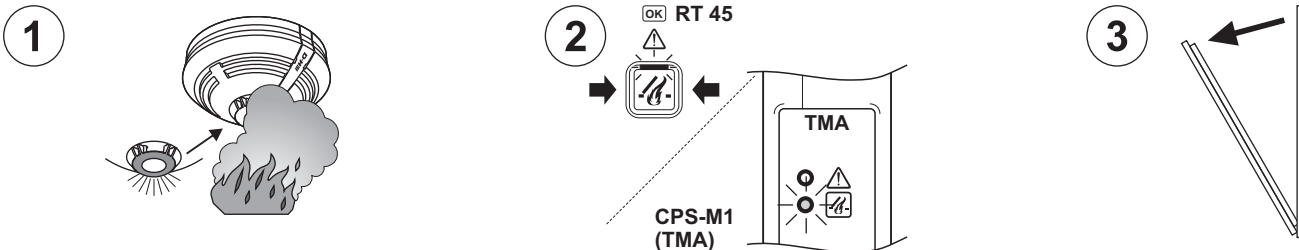

Automatic opening through external control (e.g. central fire alarm)

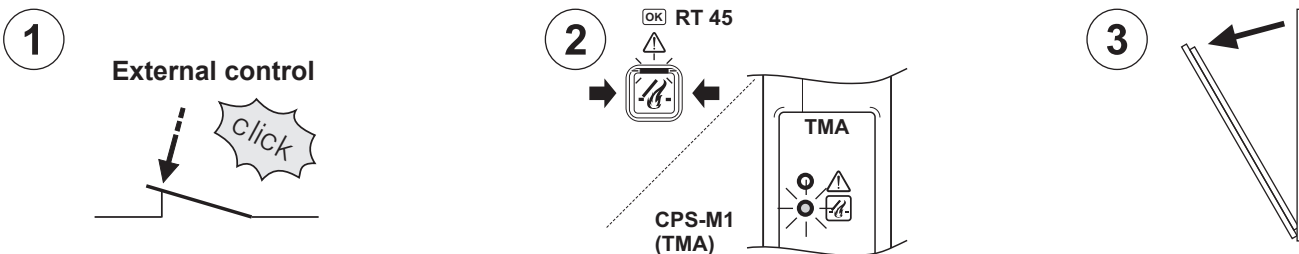

Operation - Closing after alarm

For manual triggering using smoke vent button

Opening the housing (control panel and button) using the accompanying key.

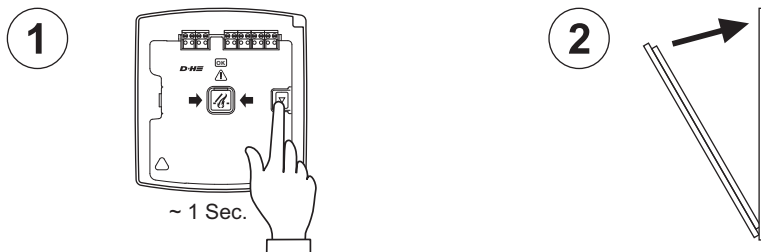

When triggered by a fire detector or external control



Emergency closing when alarm cannot be reset

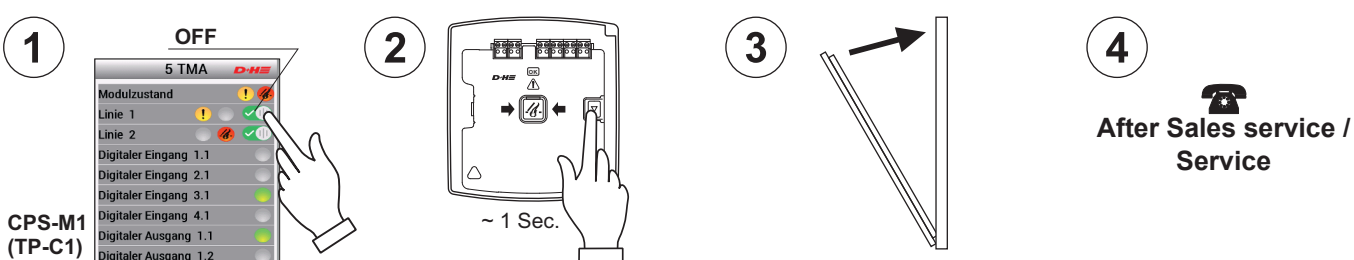

Warranty

You receive a 2-year warranty on all D+H articles from the documented date of handover until max. 3 years after the delivery date, provided that the installation/commissioning was carried out by an authorised D+H service and sales partner.

When connecting D+H components to external system or mixing D+H products with parts from other manufacturers.

Disposal

Electrical devices, accessories, batteries and packaging should be recycled in an environmentally responsible manner. Do not throw electrical devices and batteries into the household waste!

Only for EU countries:

In accordance with European Directive 2012/19/EU pertaining to waste electrical and electronic equipment and its implementation in national law, usable electrical devices must be collected separately and submitted for environmentally responsible recycling.



Inspection

Regular visual inspection between maintenance by the operator or a trained person.

Immediately correct any defects.

Displays:

- Green LEDs in the buttons must illuminate.
- Yellow LEDs in the buttons and the control panel are not allowed to illuminate or flash (fault).
- If the green LEDs do not illuminate or if the yellow LEDs illuminate or flash, contact After Sales service.

Visual inspection:

- Check all devices and cable connections for external damage and dirt.
- The function of fire detectors, smoke vent buttons, smoke extraction systems etc. must not be impaired by stored articles or structural changes.

Maintenance and cleaning

Carried out once a year by a specialist company authorised by the device manufacturer.

Carry out cleaning and maintenance work only when the system is de-energised.

Replace the inspection plate, maintain the operational book.

The inspection and maintenance must take place in accordance with the D+H maintenance instructions.

The respective current D+H maintenance instructions are authoritative.

An authorised D+H specialist company receives this automatically and has been given special training by D+H in carrying out this maintenance.

The following tests must be carried out during maintenance:

- External expert assessment / inspection of the system components
- Checking all relevant voltage supply units
- Function test of the connected system components
- Logging the proper completion of maintenance and
- Labelling in accordance with requirements

Only original D+H spare parts may be used. Repairs are carried out by D+H exclusively.

Wipe off dirt with a dry, soft cloth.

Do not use any detergents or solvents.

D+H Mechatronic AG
Georg-Sasse-Str. 28-32
22949 Ammersbek, Germany

Tel.: +4940-605 65 239
Fax: +4940-605 65 254
E-Mail: info@dh-partner.com
www.dh-partner.com
© 2016 D+H Mechatronic AG, Ammersbek

Subject to technical modifications.



99.827.31 1.2/10/17